

FULL-CIRCLE COLOR SCANNING SONAR

Model **FSV-35/35S** Low Frequency 24 kHz

Model **FSV-85** Middle Frequency 80 kHz

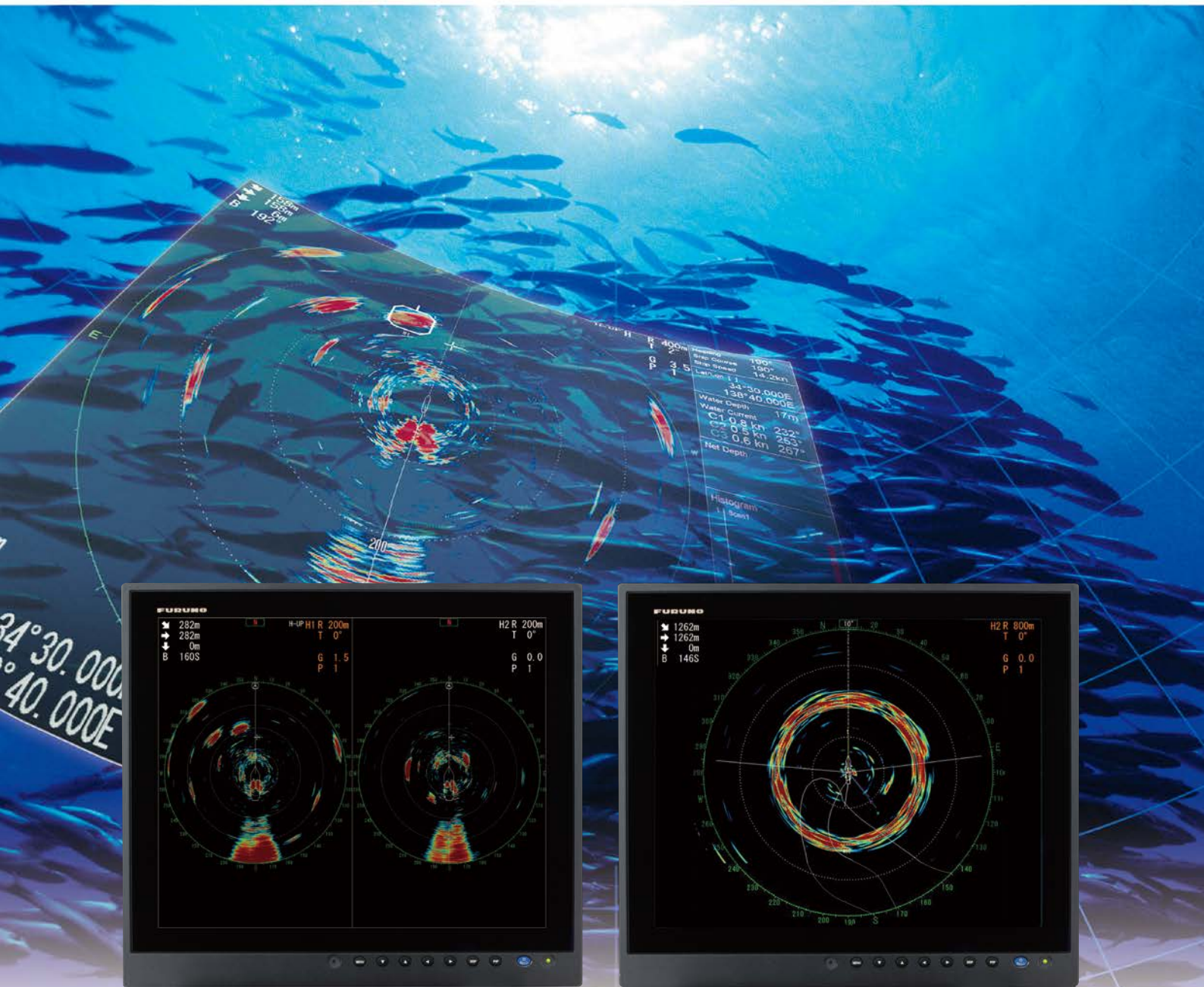

Photo: Control unit with optional monitor MU-190



The FSV series of Furuno Scanning Sonar has long been a favorite among commercial fishermen, and the FSV-35/35S/85 carries on that tradition. The FSV series provides reliable and consistent detection of fish and seabed conditions with revolutionary, enhanced signal processing technology.

To make operation even easier while underway, you can assign frequently used features to the FSV-35/35S/85's dedicated Function keys. Preset modes are also provided for instant setup of the equipment according to fishing ground or target species.

Advanced Solutions Built on



Photo: Flush mount installation



Photo: Bracket type with fixing plate

FULL-CIRCLE COLOR SCANNING SONAR

Model

FSV-35/35S

Low Frequency 24 kHz

Model

FSV-85

Middle Frequency 80 kHz



World-Proven Sonar Technology

Dual Monitors For Increased Productivity

The FSV-35/35S/85 has an ability to use a dual monitor setup to extend your sonar display across two screens. Comparing horizontal and vertical modes is easier when you have dual monitors. You can show two display modes, comparing horizontal and vertical section side by side in separate full-size windows, for example.



Horizontal Display Combinations (H2 mode)

The horizontal display mode provides a 360 degree picture around the vessel. The H2 mode shows one of four kinds of horizontal display combinations: LANDSCAPE, PORTRAIT, RIGHT INSET and LEFT INSET. The range, tilt, gain and user program are set independently, for each display.

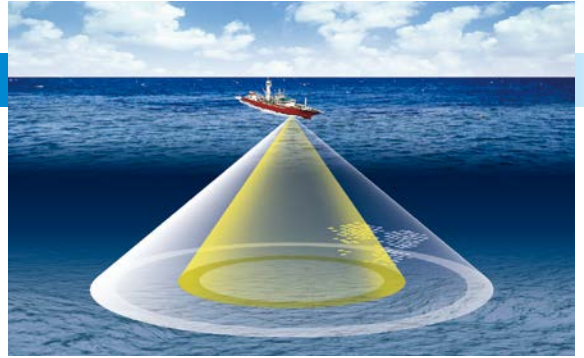

PORTRAIT



Horizontal scan 1 | Horizontal scan 2

Range: 150 m Range: 300 m
Tilt: 45 degrees Tilt: 20 degrees
Gain: 5.0 Gain: 5.0

FULL SCREEN PORTRAIT

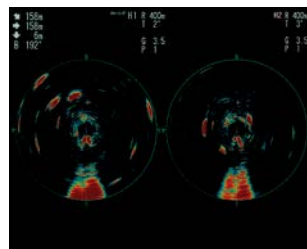

RIGHT INSET

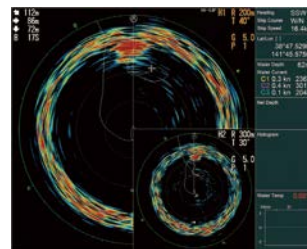

LANDSCAPE

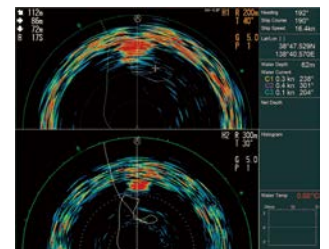

Slant Mode Scan (For FSV-85 only)

The slant mode provides a half-circle (180 degree) picture, with own ship at the center.

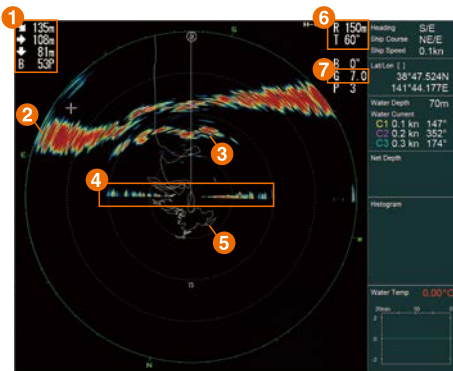
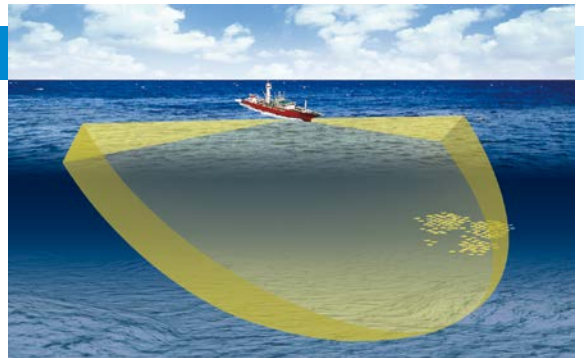

1. Direct distance, horizontal distance, water depth and bearing to the cursor
2. Seabed
3. School of fish
4. Sea surface reflection
5. Ship's track
6. Range and tilt
7. Gain

Horizontal And Vertical Display Combinations

A horizontal and two vertical scans can be displayed simultaneously. By utilizing both scans, the skipper can locate a school of fish and its distribution in horizontal and vertical perspectives at the same time.

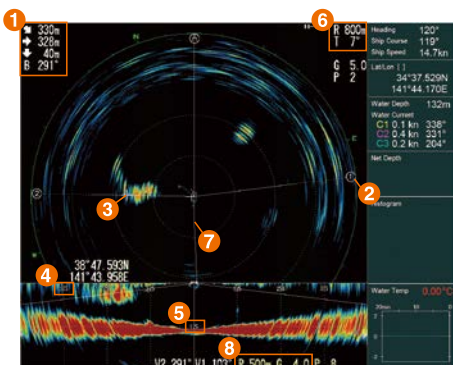
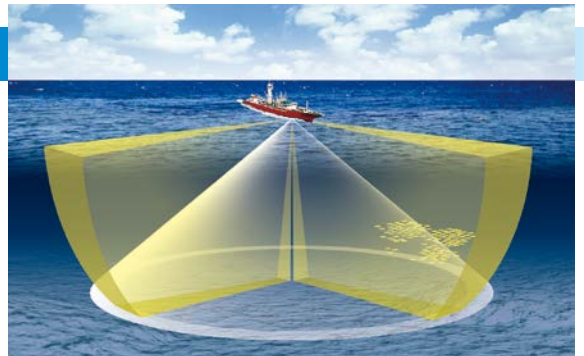

1. Direct distance, horizontal distance, water depth and bearing to the cursor
2. Bearing mark for vertical scan 1 (V1)
3. Cursor
4. Range distance of vertical scan
5. Water depth under the boat
6. Range, tilt, and display mode of Horizontal scan
7. Ship's track
8. Range and gain of vertical scan

Vertical scan 2 | Vertical scan 1

▶ High Resolution, Long Range Detection Capability

Combining the latest digital technology with a high-sensitivity transducer, the FSV-35/35S/85 provides long-range detection capability and high resolution sonar imagery.

▶ Automatic Target Lock

The echo target lock function automatically tracks the operator-selected fish school so you won't lose sight of it on the display. The range and tilt are automatically controlled according to the fish position.

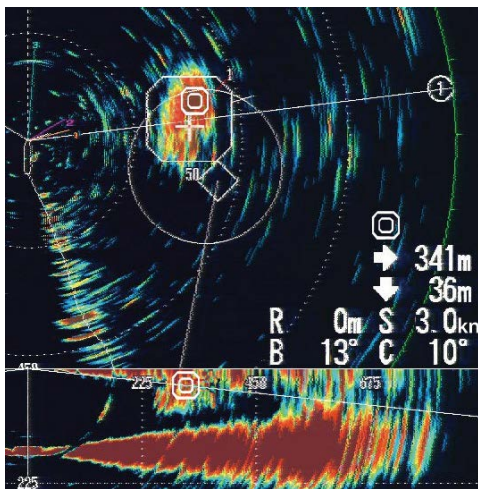

The target's range, course, and speed are automatically estimated and shown in display.

▶ Filtering For Noise Reduction

The FSV-35/35S/85's detecting system incorporates a digital filter responsive to the interfering noise, providing a clear view of the display at high speed (at 18 knots) without affecting the sonar.

▶ Beam Stabilization

The beam stabilization mode maintains the sonar beam at required tilt by compensating for ship's pitching and rolling. This gives an unwavering presentation of the echo images even in rough seas.

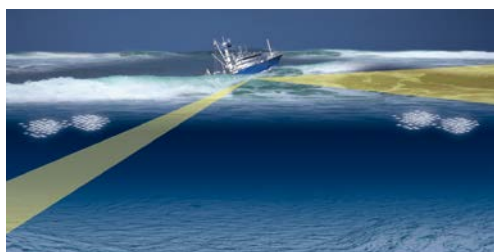

Stabilization OFF

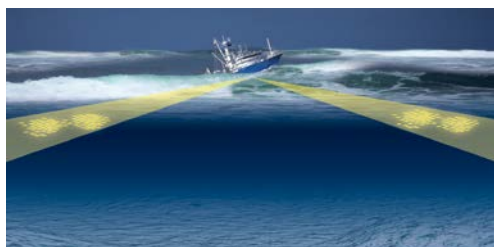

Stabilization ON

▶ Fish Histogram

The fish histogram shows, in graph form, signal strength distribution for the school(s) of fish marked with an estimate mark on the horizontal and echo sounder displays.

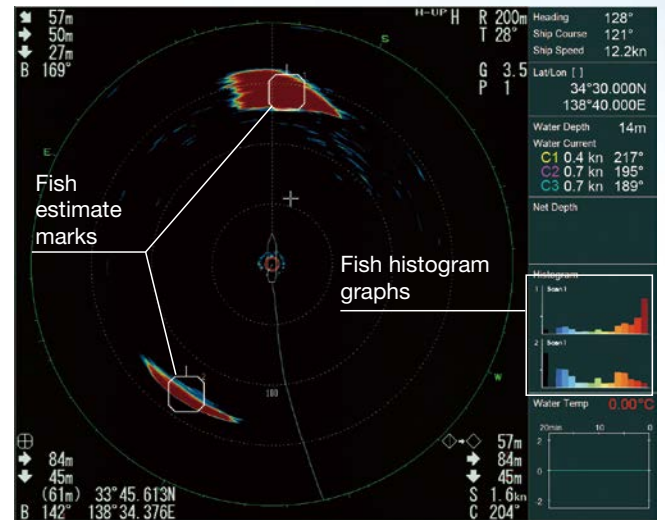

In the histogram graph at the right side of the display, the horizontal axis shows signal strength in 16 colors, and the vertical axis shows the concentration of the school of fish inside the fish estimate mark.

▶ Digital Recording Playback

FSV-35/35S/85 allows you to capture a screenshot of a sonar echo and GPS details to playback and observe targets.

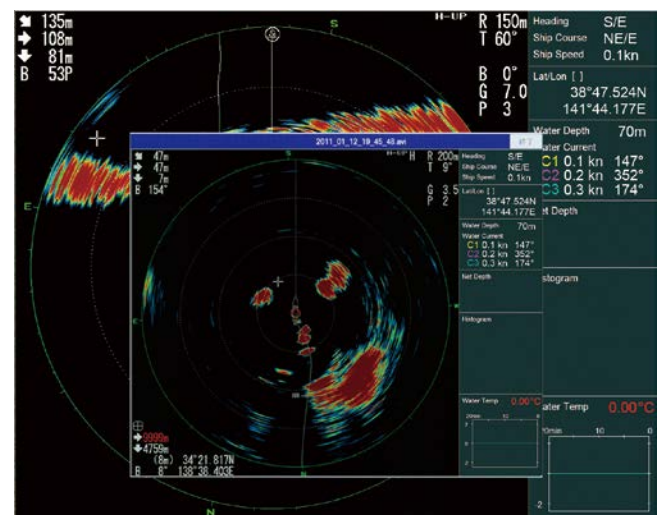

Screenshot of sonar image shown in a pop-up window.



▶ User-Friendly, Programmable, Intelligent Controls

The User Program Control provides for instant setup of the equipment according to fishing ground or target fish. Ten programs may be set up, and vertical and horizontal display settings may be programmed together or individually.

In addition, there are Function Keys at the bottom row of the control unit that let you assign up to 10 frequently used functions to them.

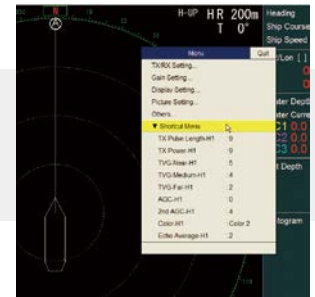

The menu setting allows you to customize the program menu you use most frequently.

▶ Control Unit Options

To enhance operator usability, a sub control unit and a wired remote controller are optionally available. Additionally, the FSV-35/35S/85 also allows the operator to use a USB wireless mouse.



Need a bright idea?

How about using FURUNO marine grade monitors in your helm?

You can select either FURUNO's lineup of marine LCDs or other third party displays.



**19" Marine Display
MU-190**

Resolution : 1280 x 1024 pixels (SXGA)
 Brightness : Max. 450 cd/m²
 Interface : Analog RGB x 1
 DVI x 2
 Composite Video x 1

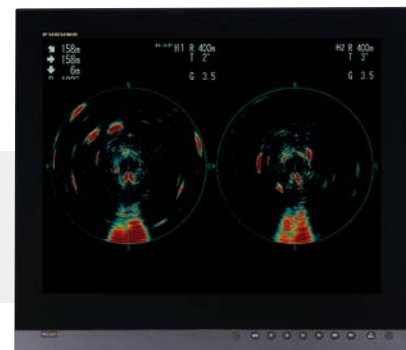

**23.1" Marine Display
MU-231**

Resolution : 1600 x 1200 pixels (UXGA)
 Brightness : Max. 400 cd/m²
 Interface : Analog RGB x 1
 DVI x 2
 Composite Video x 1

Note: When inputting SXGA, a circle may be displayed as an ellipse because the aspect ratio differs.

FULL-CIRCLE COLOR SCANNING SONAR

Model **FSV-35/35S** Low Frequency 24 kHz

CONTROL UNIT FSV-8501

3.8 kg 8.4 lb

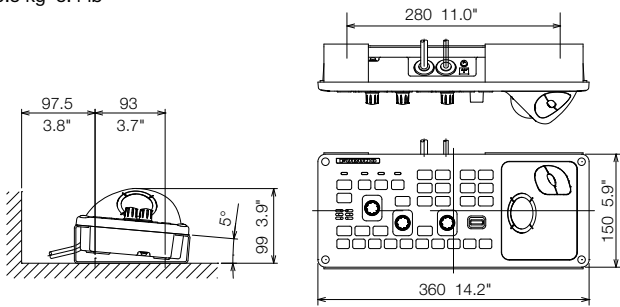

Dimensions for hanger type installation with fixing plate.
Please read installation manual for flush mount installation.

PROCESSOR UNIT FSV-3503/3503S

15 kg 33.1 lb

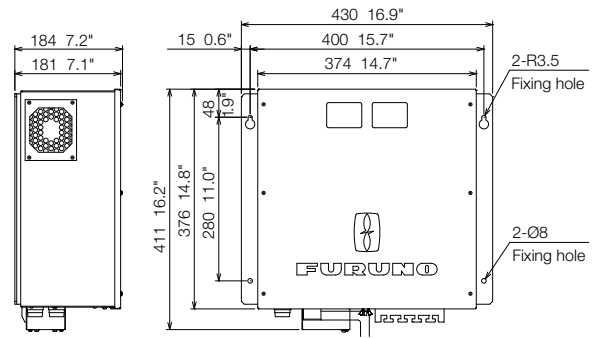

HULL UNIT FSV-303/304

1200 mm: 880 kg 1940 lb
1600 mm: 930 kg 2050 lb
(Without tank)

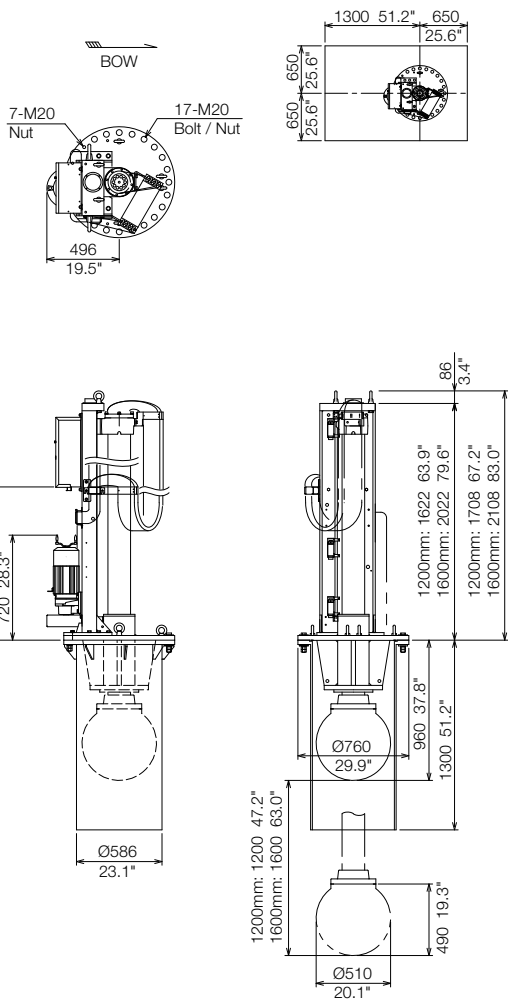

TRANSCIVER UNIT FSV-351

98 kg 216 lb

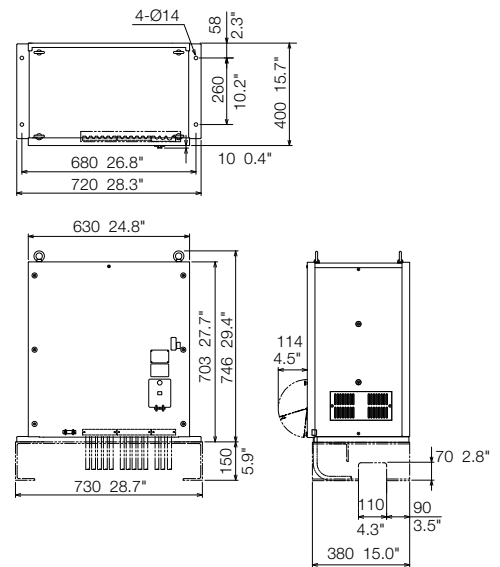

INTERFACE UNIT FSV-8502

3.4 kg 7.5 lb

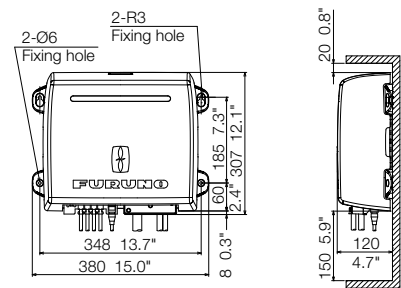

REMOTE CONTROLLER FSV-854

0.68 kg 1.5 lb

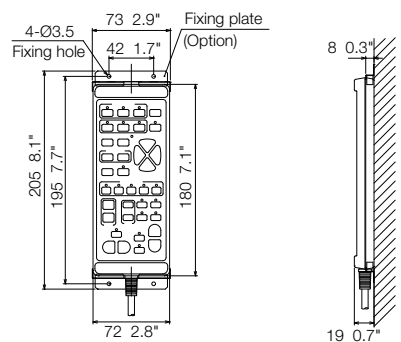

FULL-CIRCLE COLOR SCANNING SONAR

Model **FSV-35/35S** Low Frequency 24 kHz

SPECIFICATIONS

1. GENERAL

Scanning method Full digital beam forming
 Frequency 24 kHz
 Range 60, 100, 150, 200, 300, 400, 500, 600, 800, 1000, 1200, 1600, 2000, 2500, 3000, 3500, 4000, 5000, 6000*, 7000*, 8000*, 9000*, 10000* *FSV-35S only
 Audio search 30°, 60°, 90°, 180°, 330°, selectable
 Audio output Audio terminal (requires speaker with amplifier)

2. DISPLAY UNIT*

* Monitors not included as standard supply
 Screen resolution 1280(H) x 1024(V) pixels, SXGA
 Presentation colors 32 colors (sonar picture), 6 colors (marks)
 Presentation modes Horizontal, Horizontal combination, Vertical 1 combination, Vertical 2 combination
 Features Custom mode, Interference rejecter, After-glow, Noise limiter, Signal level, Auto-tilt, Automatic target tracking (target lock), Fish alarm, Over-voltage warning, Unretracted transducer warning

3. TRANSCIVER UNIT

Transmitter PDM half-bridge
 Receiving method Straight amplifier, full digital beam forming
 H-mode beam-width TX: 360° x 18°, RX: 18° x 18° (-6 dB full width)
 V-mode beam-width TX: 18° x 105°, RX: 18° x 18° (-6 dB full width)
 Tilt angle -5° to 90°
 Vertical search range 0° to 90°

4. HULL UNIT

Type	FSV-303	FSV-304
Travel	1200 mm	1600 mm
Raise/Lower time	22 sec	29 sec
Allowable ship's speed (Raise/lower operation)	18 knots (15 knots)	15 knots (12 knots)

5. DATA Input/Output

Input (NMEA 0183) CUR, DBS, DBT, DPT, GGA, GLL, GNS, HDG, HDM, HDT, MDA, MTW, MWV, RMA, RMC, VBW*¹, VDR, VHW, VTG, VWR, VWT, ZDA
¹ Fore-aft and port-stbd speeds required.
 CIF input System clock, Position, Bearing, First layer current data, Water depth, Water temperature, Sonde depth, Ship's speed/course data, Multi-layer current data, Net depth, Wind speed/direction, Sonde number
 Output (NMEA 0183) TLL

6. POWER SUPPLY

Processor unit: 12-24 VDC: 8.7 – 4.4 A (I/F unit included)
 Interface unit: 48 VDC: 2.7 A or less (from Processor unit)
 Transceiver unit: 100/110/115/220/230 VAC: 15 A, 1 phase, 50-60Hz
 Hull unit: 220 VAC: 12 A, 3 phase, 50-60Hz

7. ENVIRONMENTAL CONDITIONS

Ambient Temperature
 Processor unit: 0°C to +45°C
 Transducer: -5°C to +35°C
 Other units: 0°C to +50°C
 Relative humidity: 93% at 40°C
 Vibration: IEC 60945 4 ed.
 Waterproofing (IEC60529)
 Control unit: IP22 (panel), IP20 (chassis)
 Processor unit: IP20
 Interface unit: IP20
 Transceiver unit: IPX0
 Transducer: IPX8

EQUIPMENT LIST

Standard

- Control Unit (w/5 or 10 m cable) FSV-8501
- Interface Unit FSV-8502
- Processor Unit FSV-3503 (for FSV-35) or FSV-3503S (for FSV-35S)
- Transceiver Unit FSV-351
- Hull Unit (specify when ordering) FSV-303 or FSV-304
- Installation materials and spare parts

Option

- Rectifier
- Control Unit (w/5 or 10 m cable)
- Sub Control Unit FSV-853
- Remote Controller FSV-854-E
- Cable (5P, 100 m) 10S2380
- Installation Materials (LAN cable)
- 8-core Cable
- Cable Assy. (6P-6P, 5/10 m)
- Attachment Kit
- Hull Unit Processor Extension Kit

SYSTEM CONFIGURATION

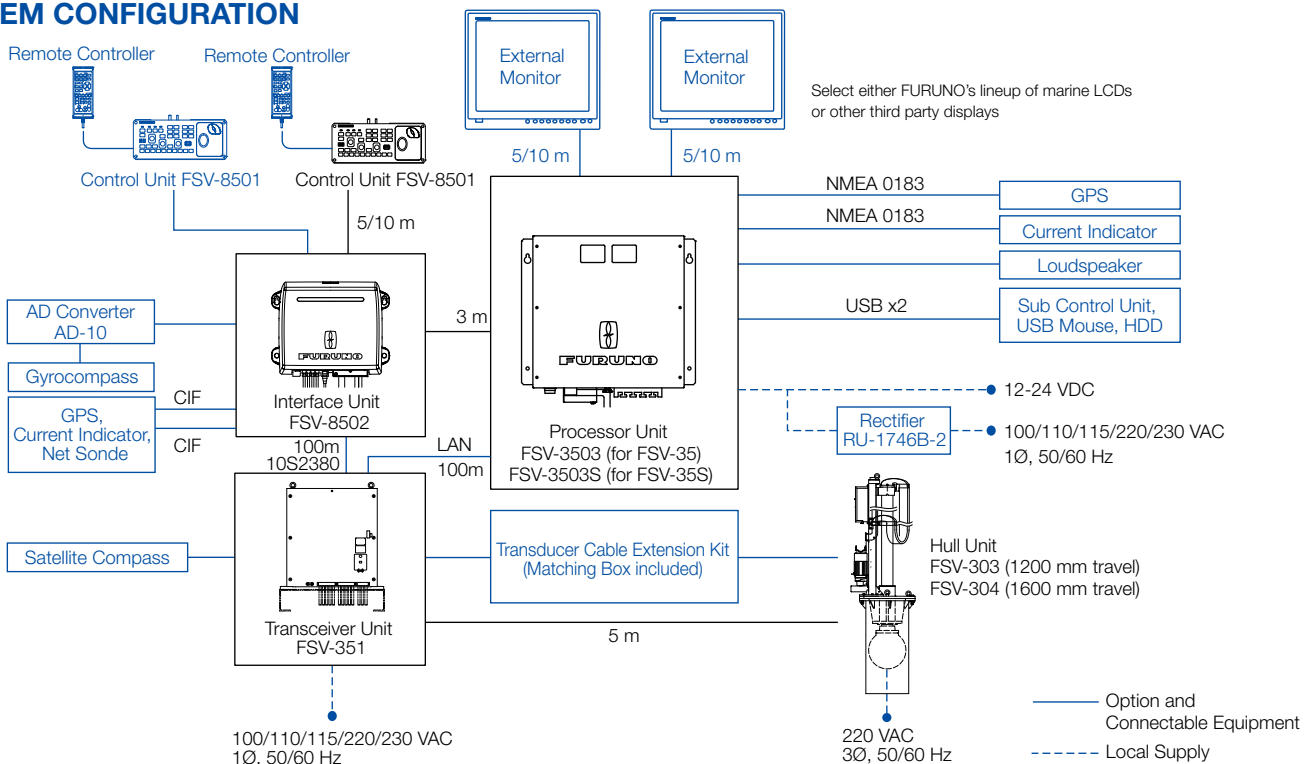

FULL-CIRCLE COLOR SCANNING SONAR

Model **FSV-85** Middle Frequency 80 kHz

SPECIFICATIONS

1. GENERAL

Scanning method Full digital beam forming
 Frequency 80 kHz
 Range 60, 100, 150, 200, 300, 400, 500, 600, 700, 800, 900, 1000, 1100, 1200, 1400, 1600, 2000 m
 Audio search 30°, 60°, 90°, 180°, 330°, selectable
 Audio output Audio terminal (requires speaker with amplifier)

2. DISPLAY UNIT*

Monitors not included as standard supply
 Screen resolution SXGA (1280 X 1024), USGA (1600 X 1200), WUXGA (1920 X 1200)
 Presentation colors 32 colors (sonar picture), 6 colors (marks)
 Presentation modes Horizontal, S-scan, Horizontal combination, S-scan combination, Vertical 1 combination, Vertical 2 combination
 Features Custom mode, Interference rejecter, After-glow, Noise limiter, Signal level, Auto-tilt, Automatic target tracking (target lock), Fish alarm, Over-voltage warning, Unretracted transducer warning

3. TRANSCIVER UNIT

Transmitter PDM half-bridge
 Receiving method Straight amplifier, full digital beam forming
 H-mode beam-width TX: 360° x 10.7°, RX: 12.6° x 10.1° (-6 dB full width)
 V-mode beam-width TX: 12.7° x 118.2°, RX: 12.6° x 12.1° (-6 dB full width)
 S-mode beam-width TX: 206.7° x 12.1°, RX: 12.6° x 12.0° (-6 dB full width)
 Tilt angle -5° to 90° (downward)
 Vertical search range 0° to 90° (downward)

4. HULL UNIT

Type	FSV-8432	FSV-8442
XDCR travel	800 mm	1100 mm
Raise/Lower time	21 sec	28 sec
Allowable ship's speed (Raise/lower operation)	18 knots (18 knots)	15 knots (15 knots)

5. DATA Input/Output

Input (NMEA 0183) CUR, DBS, DBT, DPT, GGA, GLL, GNS, HDG, HDM, HDT, MDA, MTW, MWV, RMA, RMC, VBW*, VDR, VHW, VTG, VWR, VWT, ZDA
 *1 Fore-aft and port-stbd speeds required.
 CIF input System clock, Position, Bearing, First layer current data, Water depth, Water temperature, Sonde depth,

Ship's speed/course data, Multi-layer current data, Net depth, Wind speed/direction, Sonde number
 Output (NMEA 0183) TLL

6. POWER SUPPLY

Processor unit: 12-24 VDC: 10-5 A
 Interface unit: 48 VDC: 1 A or less (from Processor unit)
 Transceiver unit: 100/110/115/220/230 VAC: 15 A, 1 phase, 50/60Hz
 Hull unit: 200-220 VAC: 4 A, 3 phase, 50/60Hz

7. ENVIRONMENTAL CONDITIONS

Ambient Temperature
 Processor unit: 0°C to +45°C
 Transducer: -5°C to +35°C
 Other units: 0°C to +50°C
 Relative humidity: 93% max. at 40°C
 Vibration: IEC 60945 4 ed.
 Waterproofing (IEC 60529)
 Control unit: IP22 (panel), IP20 (chassis)
 Processor unit: IP20
 Interface unit: IP20
 Transceiver unit, others: IPX0
 Transducer: IPX8

EQUIPMENT LIST

Standard

- Control Unit (w/5 or 10 m cable) FSV-8501
- Interface Unit FSV-8502
- Processor Unit FSV-8503
- Transceiver Unit FSV-851A
- Hull Unit (specify when ordering) FSV-8432-T or FSV-8442-T
- Installation materials and spare parts

Option

- Rectifier
- Control Unit (w/5 or 10 m cable)
- Remote Controller FSV-854-E
- Cable (5P, 100 m) 10S2380
- Installation Materials (LAN cable)
- 8-core Cable (6m)
- Cable Assy. (6P-6P, 5/10 m)
- Retraction Tank
- Attachment Kit
- Junction Box (NMEA0183)
- Sub Control Unit

SYSTEM CONFIGURATION

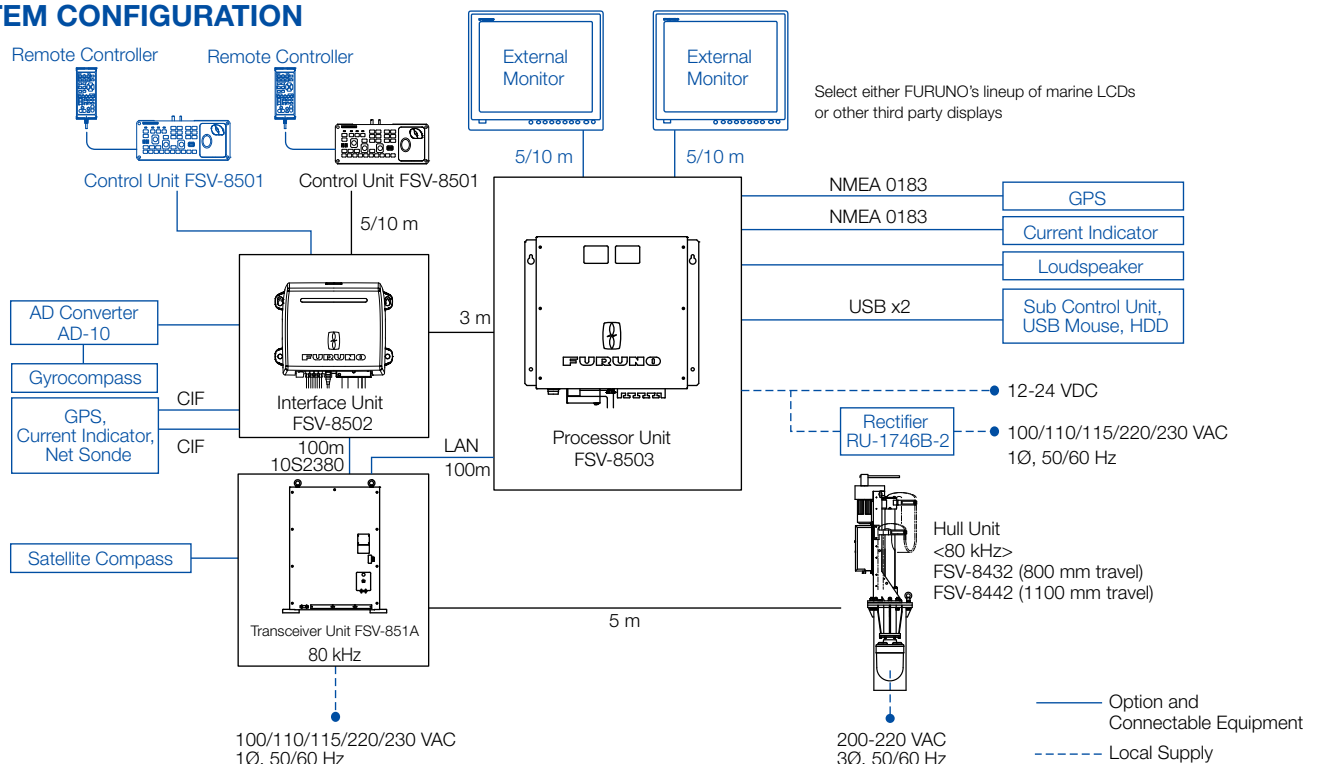

FULL-CIRCLE COLOR SCANNING SONAR

Model **FSV-85** Middle Frequency 80 kHz

FURUNO

CONTROL UNIT FSV-8501

3.8 kg 8.4 lb

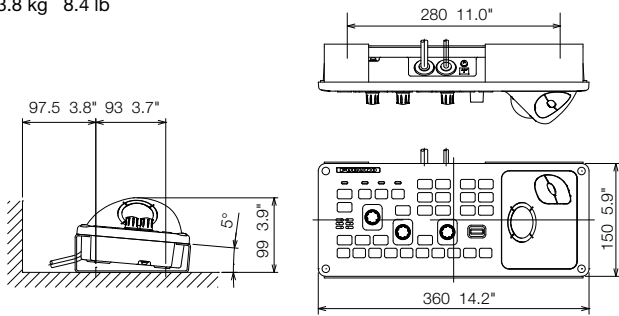

Dimensions for hanger type installation with fixing plate.
Please read installation manual for flush mount installation.

PROCESSOR UNIT FSV-8503

15 kg 33.1 lb

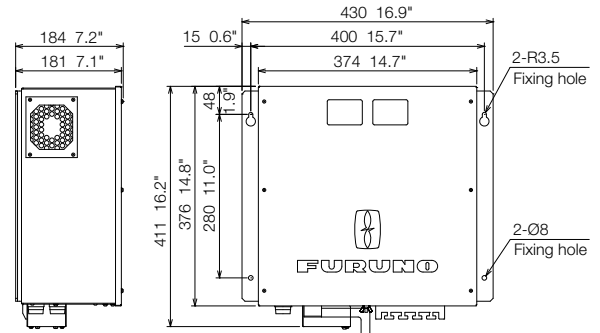

HULL UNIT FSV-8432/8442

800 mm: 370 kg 815.7 lb
1100 mm: 390 kg 859.8 lb
(With tank)

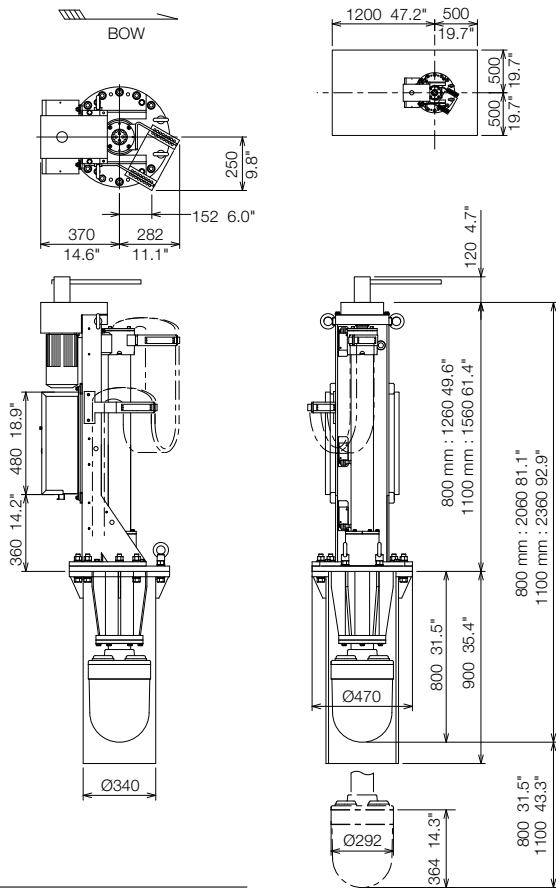

800 mm FSV-8432 With motion sensor
1100 mm FSV-8442 With motion sensor

TRANSCIVER UNIT FSV-851

95 kg 209.4 lb

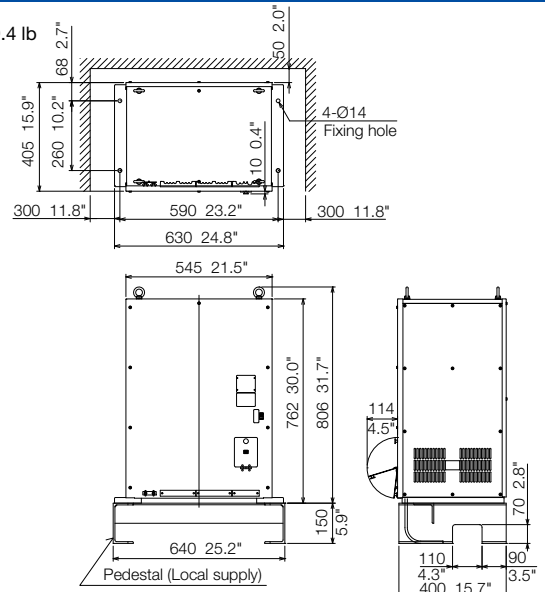

INTERFACE UNIT FSV-8502

3.4 kg 7.5 lb

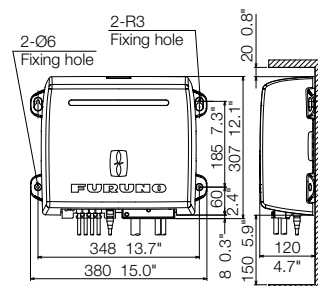

REMOTE CONTROLLER FSV-854

0.68 kg 1.5 lb

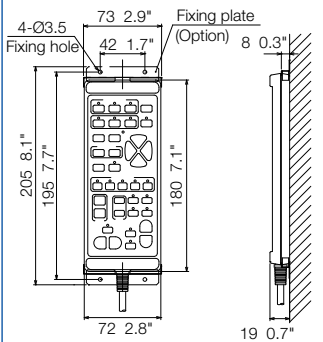

Beware of similar products

All brand and product names are registered trademarks, trademarks or service marks of their respective holders.

SPECIFICATIONS SUBJECT TO CHANGE WITHOUT NOTICE

FURUNO ELECTRIC CO., LTD.

Nishinomiya, Hyogo, Japan
www.furuno.com

FURUNO U.S.A., INC.

Camas, Washington, U.S.A.
www.furunousa.com

FURUNO (UK) LIMITED

Havant, Hampshire, U.K.
www.furuno.co.uk

FURUNO FRANCE S.A.S.

Bordeaux-Mérignac, France
www.furuno.fr

FURUNO ITALIA S.R.L.

Gatteo Mare, Italy
www.furuno.it

FURUNO ESPAÑA S.A.

Madrid, Spain
www.furuno.es

FURUNO DANMARK A/S

Hvidovre, Denmark
www.furuno.dk

FURUNO NORGE A/S

Ålesund, Norway
www.furuno.no

FURUNO SVERIGE AB

Västra Frölunda, Sweden
www.furuno.se

FURUNO FINLAND OY

Espoo, Finland
www.furuno.fi

FURUNO POLSKA Sp. z o.o.

Gdynia, Poland
www.furuno.pl

FURUNO EURUS LLC

St. Petersburg, Russian Federation
www.furuno.ru

FURUNO SINGAPORE

Singapore
www.furuno.sg

FURUNO DEUTSCHLAND GmbH

Rellingen, Germany
www.furuno.de

FURUNO HELLAS S.A.

Piraeus, Greece
www.furuno.gr

FURUNO (CYPRUS) LTD

Limassol, Cyprus
www.furuno.com.cy

FURUNO CHINA CO., LTD.

Hong Kong
www.furuno.com/cn

FURUNO SHANGHAI CO., LTD.

Shanghai, China
www.furuno.com/cn

Catalogue No. CA00001121

1-B-1706PDF