

FURUNO

10.4" LCD, Compact and High accuracy

DOPPLER SONAR CURRENT INDICATOR

Model **CI-88**



- Compact design and single-mold transducer for ease of installation and maintenance
- High definition 10.4" color LCD for displaying tide current detections
- Blackbox system configuration allows use of commercial VGA monitors
- Continuous display of tide speed and direction at the three selected depth layers
- Tide speed/direction and ship's track can be plotted on screen for larger area tide observation
- Triple-beam system for less error in tide current detection
- True tide current presentation with external GPS navigator and Gyrocompass inputs at deep water locations
- Water temperature graph helps locate current rip (Temperature sensor required)



The FURUNO CI-88 is a Doppler Sonar Current Indicator designed for every type of fishing vessels and hydrographic survey vessels. The high-definition 10.4" color LCD continuously presents tide speed and direction at three depth layers simultaneously in addition to ship's speed and drift. This variety of current information allows you to predict net shape and plan when to throw your net.

There are six presentation modes: tide vector, ship's speed, echo level, text, track and tide log. Mode selection is simple by pressing the dedicated button. Other menu settings are also easily made by using the cursor pad or rotary knob. The CI-88 features the unique, user customizable "function button" to shortcut menu operation. Once you have registered the often-used function, then just press the dedicated button and then the function window pops up.

The CI-88 has a triple-beam emission system for providing highly accurate current measurement. This system greatly reduces the effects of rolling, pitching and heaving motions, providing a continuous display of tide information.

There are four modes for measurement: ground tracking, water tracking, NAV and Automatic. In the NAV mode, when ground (bottom) reference is not available acoustically in deep water, the CI-88 can provide true tide current information by receiving position data from a GPS navigator and heading data from a gyrocompass or a GPS compass.

The CI-88 consists of a display unit, a processor unit and a transducer. The control unit and display unit can be installed separately for flexible installation. A BlackBox configuration (without monitor) is also available.

Increase your fishing efficiency by using highly accurate current information

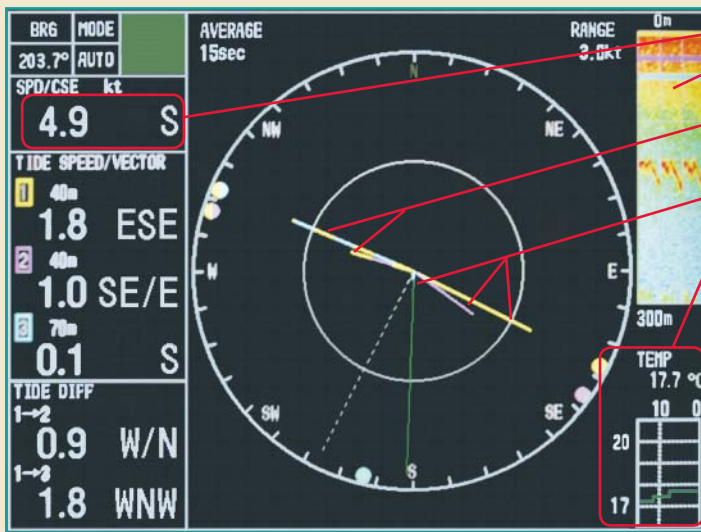

- Ship's speed and course
- Echograms
- Tide vectors for tide differences Layer 1 and 2
- Layer 1 and 3
- Tide vectors for speed and direction Layer 1, 2 and 3
- Water temperature (external temp. sensor required)

TIDE VECTOR

Tide speed and direction for the three depth layers are displayed with vectors. The depth of each layer can be set manually in 1 m intervals. Other information such as tide differential between the reference and one of the two other layers, heading and course can also be displayed in large text.



SHIP'S SPEED

Displays the speed components for fore-aft and port-stbd. The synthesized vector (green line) intuitively shows drift direction. The speed source is selectable on the menu from ground tracking or water tracking.

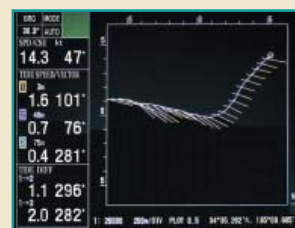

TRACK

Tide vectors can be shown on the ship's track in user-specified intervals.



ECHO LEVEL

Displays echogram obtained from each beam. It helps evaluate the concentration or distribution of fish school or seabed at three directions simultaneously.



TIDE LOG

Displays the tide information over the past twelve hours.



TEXT

INTERCONNECTION DIAGRAM

Standard configuration (with standard LCD monitor)

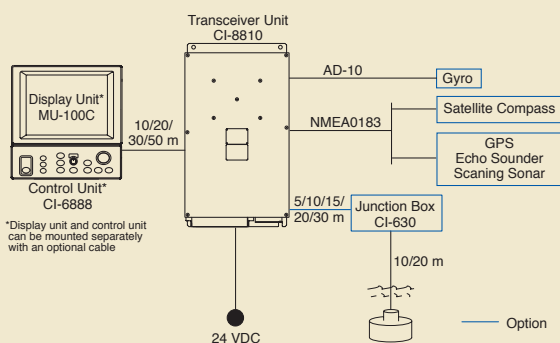

BlackBox configuration (with custom monitor)

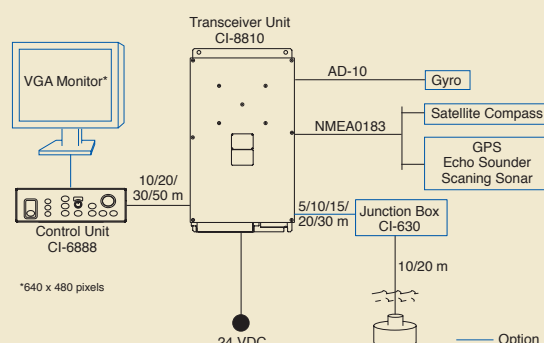

*Display unit and control unit can be mounted separately with an optional cable

*640 x 480 pixels

SPECIFICATIONS OF CI-88

Display

10.4" TFT color LCD, 640 x 480 pixels

Measurements

Current

Speed: 0 to 9.9 kt
 Direction: 0 to 360°
 Number of layers: 3 layers

Ship

Speed: -10 to 30 kt (fore-aft)
 -9.9 to +9.9 kt (port-starboard)
 Direction: 0 to 360°

Depth Range

For current measurement

2 to 75% of water depth up to 100 m
 (Over 10 m of water depth is required in Ground tracking mode. Over 40 m water depth is required in Water Tracking mode.)

For ground tracking

3 to 200 m

Accuracy

Current: ± 2% of ship's speed + 0.2 kt
 Ship's speed: ± 1% + 0.1 kt

Number of Beams Three beams

Tilt 60° each

System Frequency 288 kHz

Data Interface (NMEA 0183 Ver.1.5/2.0/3.0, IEC 61162)

Inputs:

DBT, DPT (Depth), GGA, GLL, RMA, RMC (L/L),
 HDG, HDM, HDT (Compass), MTW (Water temperature),
 VTG (SOG, COG), ZDA (UTC)

Outputs:

CUR (Water current layer), VBW (Dual Ground/Water Speed),
 VDR (Set and Drift), VHW (Water speed and heading), VLW
 (Distance travelled through the water), VTG (SOG, COG)

ENVIRONMENTAL (IEC 60945 test method)

Temperature Display Unit: -15° to +55°
 Control Unit: -15° to +55°
 Transceiver Unit: -15° to +55°

Waterproofing Display Unit: IPX0 (IEC 60529)
 Control Unit: IPX2 (IEC 60529)
 Transceiver Unit: IPX0 (IEC 60529)

POWER SUPPLY

24 VDC, 110 W (TX)

EQUIPMENT LIST

Standard

- | | |
|---|--------|
| 1. Display Unit MU-100C | |
| 2. Control Unit CI-6888 | 1 unit |
| 3. Transceiver Unit CI-8810 | 1 unit |
| 4. Transducer CI-8840-1 with 10 m cable | 1 unit |
| 5. Thru-hull Pipe for steel hull TFB-5000CI | 1 pc |
| 6. Installation materials and spare parts | 1 set |

Optional

- Junction Box CI-630
- Transducer CI-8840-2 with 20 m cable
- Transducer Tank CI-820/821/822/823
- Cable for Transceiver - Junction box Z-6FVNV-SX-C, 5/10/15/20/30 m
- Cable for Display - Control Unit 66S1239-0, 5/10 m

Display Unit and Control Unit

MU-100C and CI-6888 6.0 kg, 13.2 lb

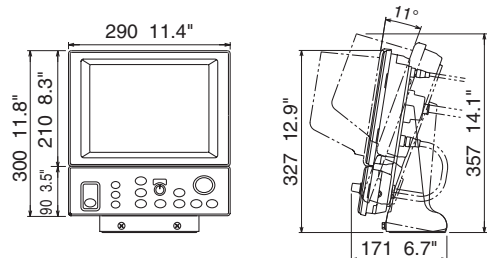

Flush Mount Type 6.0 kg, 13.2 lb

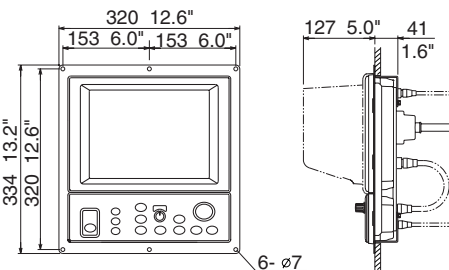

Transceiver Unit

CI-8810 12.0 kg, 26.5 lb

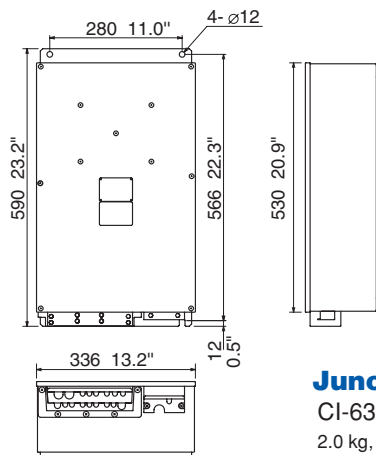

Transducer

CI-8840-1 with 10 m cable 6.1 kg, 13.4 lb
 CI-8840-2 with 20 m cable 8.9 kg, 19.6 lb

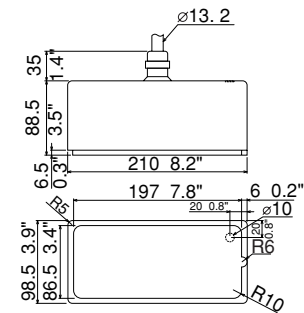

Junction Box

CI-630
 2.0 kg, 4.4 lb

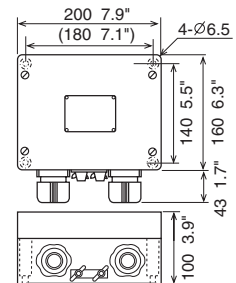

TRADEMARK REGISTERED MARCA REGISTRADA
 SPECIFICATIONS SUBJECT TO CHANGE WITHOUT NOTICE

FURUNO ELECTRIC CO., LTD.

Nishinomiya, Hyogo, Japan
 Phone: +81 (0)798 65-2111
 Fax: +81 (0)798 65-4200, 66-4622

FURUNO U.S.A., INC.

Camas, Washington, U.S.A.
 Phone: +1 360-834-9300
 Fax: +1 360-834-9400

FURUNO (UK) LIMITED

Havant, Hampshire, U.K.
 Phone: +44 23 9244 1000
 Fax: +44 23 9248 4316

FURUNO FRANCE S.A.

Bordeaux-Mérignac, France
 Phone: +33 5 56 13 48 00
 Fax: +33 5 56 13 48 01

FURUNO ESPAÑA S.A.

Madrid, Spain
 Phone: +34 91-725-90-88
 Fax: +34 91-725-98-97

FURUNO DANMARK AS

Hvidovre, Denmark
 Phone: +45 36 77 45 00
 Fax: +45 36 77 45 01

FURUNO NORGE A/S

Ålesund, Norway
 Phone: +47 70 102950
 Fax: +47 70 102951

FURUNO SVERIGE AB

Västra Frölunda, Sweden
 Phone: +46 31-7098940
 Fax: +46 31-497093

FURUNO FINLAND OY

Espoo, Finland
 Phone: +358 9 4355 670
 Fax: +358 9 4355 6710

FURUNO POLSKA Sp. Z o.o.

Gdynia, Poland
 Phone: +48 58 669 02 20
 Fax: +48 58 669 02 21

FURUNO DEUTSCHLAND GmbH

Rellingen, Germany
 Phone: +49 4101 838 0
 Fax: +49 4101 838 111

LLC "FURUNO EURUS"

St. Petersburg, Russian Federation
 Phone: +7 812 767 15 92
 Fax: +7 812 766 55 52



08073KS Printed in Japan
 Catalogue No. M-1531a

