



**FURUNO**

AIS RECEIVER

Model

**FA-30**



# Information to navigation systems in all weather conditions

## What is AIS?

The Automatic Identification System (AIS) enhances safe navigation by exchanging critical navigational data with nearby AIS-enabled targets. The system utilizes VHF broadcasts to handle information about nearby vessel traffic as well as aids-to-navigation.

AIS data includes vessel's name, position and course/speed over ground, allowing you to predict the course changes of other vessels. And since AIS targets are constantly visible even when they are shrouded in fog, in darkness, behind capes, river bends and other obstructions, this system helps you to avoid dangerous collisions.

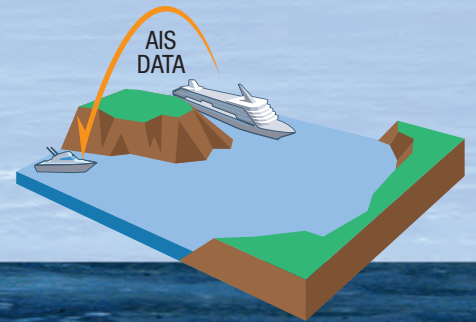

- Enhances safe navigation by receiving critical navigation information from local AIS-equipped vessels
- Vastly improves situational awareness in any weather conditions including dense fog, darkness, and congested waterways
- Dual parallel channel, “Full Duplex” receiver design receives AIS contact messages up to 100% more often than dual channel “Multiplexing” receivers
- High sensitivity, synthesized receiver automatically switches between international and local AIS channels
- Optional amplified VHF splitter allows the use of a single antenna for VHF radio and AIS Receiver
- Network output to NavNet and PCs for added redundancy and installation flexibility
- Serial Output for integration with various radar and chart plotter systems
- Bulkhead mounting and low power, flexible DC input voltage design for simplified installations

# The FA-30 delivers “Real-Time” AIS information providing critical collision avoidance information

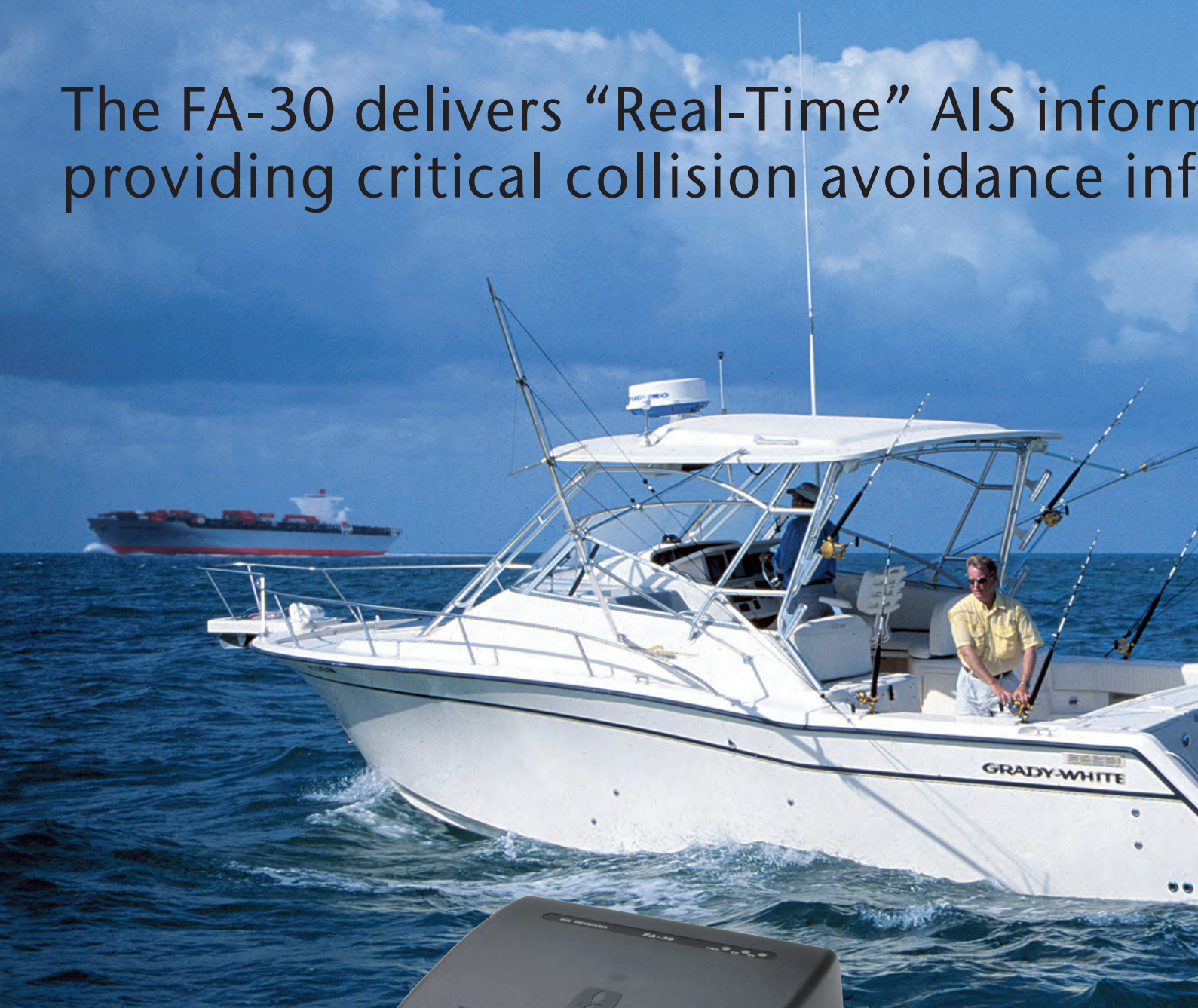

**FA-30**  
AIS RECEIVER

Acquisition and tracking of traffic around your vessel is absolutely necessary for safe and efficient navigation. FURUNO's FA-30 AIS Receiver provides navigational data about other AIS-equipped vessels, increasing your situational awareness and allowing you to navigate more safely.

The FA-30 incorporates real-time AIS information into your radar, chart plotter.

AIS targets are displayed with SOG/COG vector, which aids you in recognizing possible collisions and grasp the navigational situation at a glance, even in congested waterways. Closest Point of Approach (CPA) and Time to Closest Point of Approach (TCPA) can be computed and displayed on-screen.

The FA-30 outputs AIS data to NavNet series. The FA-30 can also be interfaced with a FURUNO radar or chart plotter via NMEA0183 format to supplement those systems.

# Information to navigation systems in all weather conditions



## Information to be received

### Dynamic Data

- Ship's position
- Course over ground (COG)
- Speed over ground (SOG)
- Rate of turn (ROT)
- Heading
- Navigation status\*

### Static Data

- MMSI (Maritime Mobile Service Identity)
- IMO number\*
- Ship's name
- Type of ship
- Call sign
- Length and beam
- Location of position-fixing antenna on the ship

### Voyage Related Data

- Ship's draft\*
- Hazardous cargo
- Destination and ETA\*

### Safety-related messages

\* Class-A AIS only

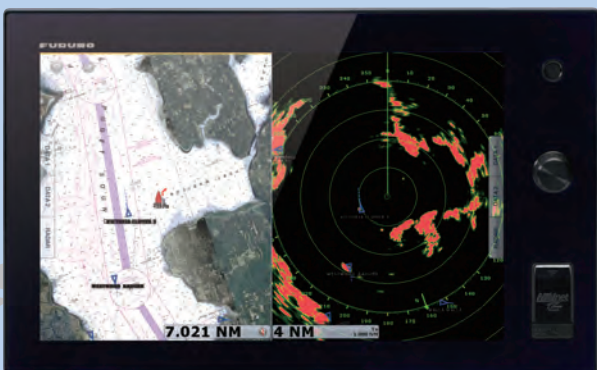

**NAVnet**  
TZ  
touch



**NAVnet**  
TZ2  
touch



NavNet TZtouch2

When placing a cursor onto the AIS target, an AIS data window will pop up to display the following data of the target: Ship's name, COG, SOG, CPA, TCPA, Range and Bearing.



### Radar FR-8xx5 series

When interfacing with FR-8xx5 series, AIS interface IF-1500AIS is needed.

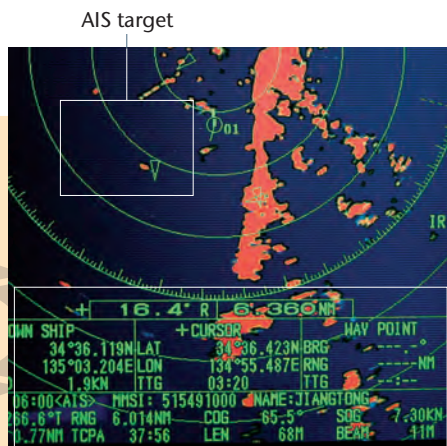

AIS target

AIS information

### AIS target symbol

COG/SOG vector changes its length according to SOG.  
ROT mark is viewable when the target vessel sends the information.  
Past track dots enables you to evaluate the target's action.

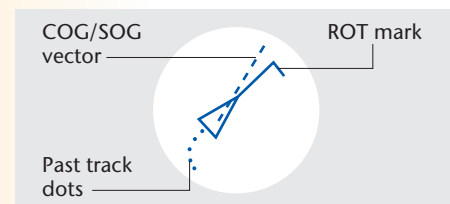

# SPECIFICATIONS OF

Model **FA-30**

## STANDARDS REFERRED

IMO Res. MSC.74 (69) Annex 3, ITU-R Rec. M.1371-2  
IEC 61993-2 Ed.1 (Class-A AIS), IEC 62287-1 (Class-B CS-TDMA AIS),  
IEC 60945 Ed.4, IMO Res. A.917 (22)

## RECEIVING UNIT

RX Frequency 156.025 MHz to 162.025 MHz  
Channel Spacing 25 kHz/12.5 kHz

## INTERFACE

NMEA0183

Input: ACK, ACA, AIQ, DTM, GBS, GGA, GLL,  
GNS, HDT, OSD, RMC, VBW, VTG, DSC,  
DSE, ZDA

Output (38.4kbps): VDM, VDO, ACA, ACS, ALR, TXT

Ethernet 10/100BASE-T

## POWER SUPPLY

12-24 VDC, 1.2-0.6 A

## ENVIRONMENT

Temperature (IEC 60945 Ed.4) -15 to +55 °C  
Humidity (IEC 60945 Ed.4) +40 °C, 93%RH  
Waterproofing (IEC 60529) IP20

## EQUIPMENT LIST

Standard

1. AIS Receiver FA-30  
with a Power/Serial combined cable 1 unit
2. Installation Materials and Spare Parts 1 set

Option

1. VHF Splitter Kit OP05-106
2. VHF Antenna FAB-151D
3. LAN Cable (2/10 m) for the connection with a PC
4. LAN Cable (1/5/10/20/30 m) for the connection with NavNet

## AIS RECEIVER

1.5 kg 3.3 lb

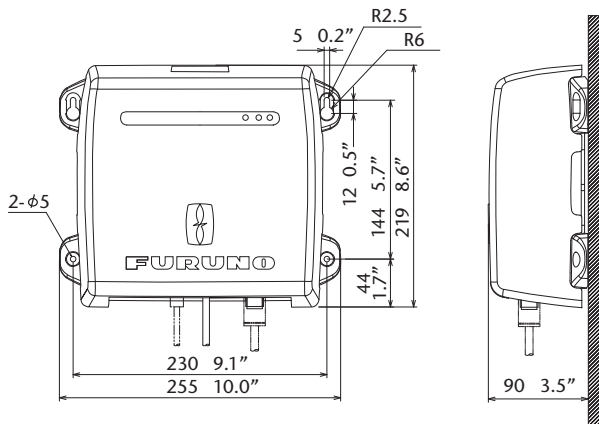

## INTERCONNECTION DIAGRAM

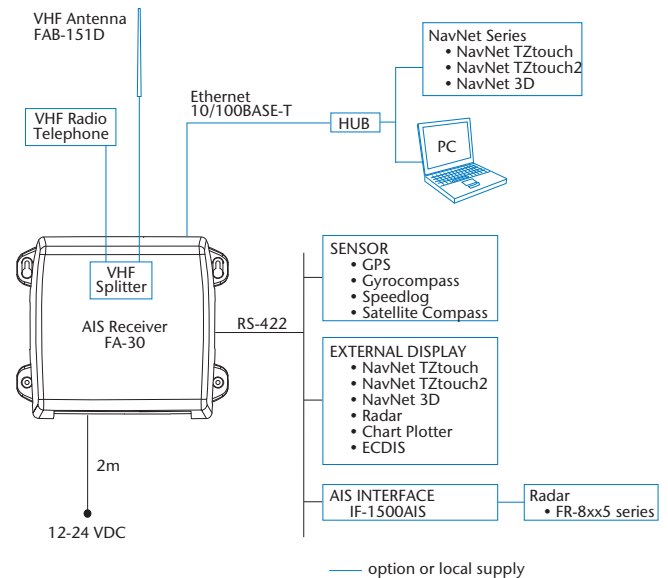

Beware of similar products

All brand and product names are registered trademarks, trademarks or service marks of their respective holders.

SPECIFICATIONS SUBJECT TO CHANGE WITHOUT NOTICE

**FURUNO ELECTRIC CO., LTD.**  
Japan | [www.furuno.com](http://www.furuno.com)

**FURUNO U.S.A., INC.**  
U.S.A. | [www.furunousa.com](http://www.furunousa.com)

**FURUNO PANAMA S.A.**  
Republic of Panama | [www.furuno.com.pa](http://www.furuno.com.pa)

**FURUNO (UK) LIMITED**  
U.K. | [www.furuno.co.uk](http://www.furuno.co.uk)

**FURUNO NORGE A/S**  
Norway | [www.furuno.no](http://www.furuno.no)

**FURUNO DANMARK A/S**  
Denmark | [www.furuno.dk](http://www.furuno.dk)

**FURUNO SVERIGE AB**  
Sweden | [www.furuno.se](http://www.furuno.se)

**FURUNO FINLAND OY**  
Finland | [www.furuno.fi](http://www.furuno.fi)

**FURUNO POLSKA Sp. z o.o.**  
Poland | [www.furuno.pl](http://www.furuno.pl)

**FURUNO DEUTSCHLAND GmbH**  
Germany | [www.furuno.de](http://www.furuno.de)

**FURUNO FRANCE S.A.S.**  
France | [www.furuno.fr](http://www.furuno.fr)

**FURUNO ESPAÑA S.A.**  
Spain | [www.furuno.es](http://www.furuno.es)

**FURUNO ITALIA S.R.L.**  
Italy | [www.furuno.it](http://www.furuno.it)

**FURUNO HELLAS S.A.**  
Greece | [www.furuno.gr](http://www.furuno.gr)

**FURUNO (CYPRUS) LTD**  
Cyprus | [www.furuno.com.cy](http://www.furuno.com.cy)

**FURUNO SHANGHAI CO., LTD.**  
China | [www.furuno.com/cn](http://www.furuno.com/cn)

**FURUNO CHINA CO., LTD.**  
Hong Kong | [www.furuno.com/cn](http://www.furuno.com/cn)

**FURUNO KOREA CO., LTD**  
Korea

**FURUNO SINGAPORE**  
Singapore | [www.furuno.sg](http://www.furuno.sg)

**PT FURUNO ELECTRIC INDONESIA**  
Indonesia | [www.furuno.id](http://www.furuno.id)

**FURUNO ELECTRIC (MALAYSIA) SND. BHD.**  
Malaysia | [www.furuno.my](http://www.furuno.my)

A-2211LB

Catalogue No. CA000001738