

**FURUNO**

# 360-DEGREE OMNI SCANNING SONAR

Model

# CSH-10

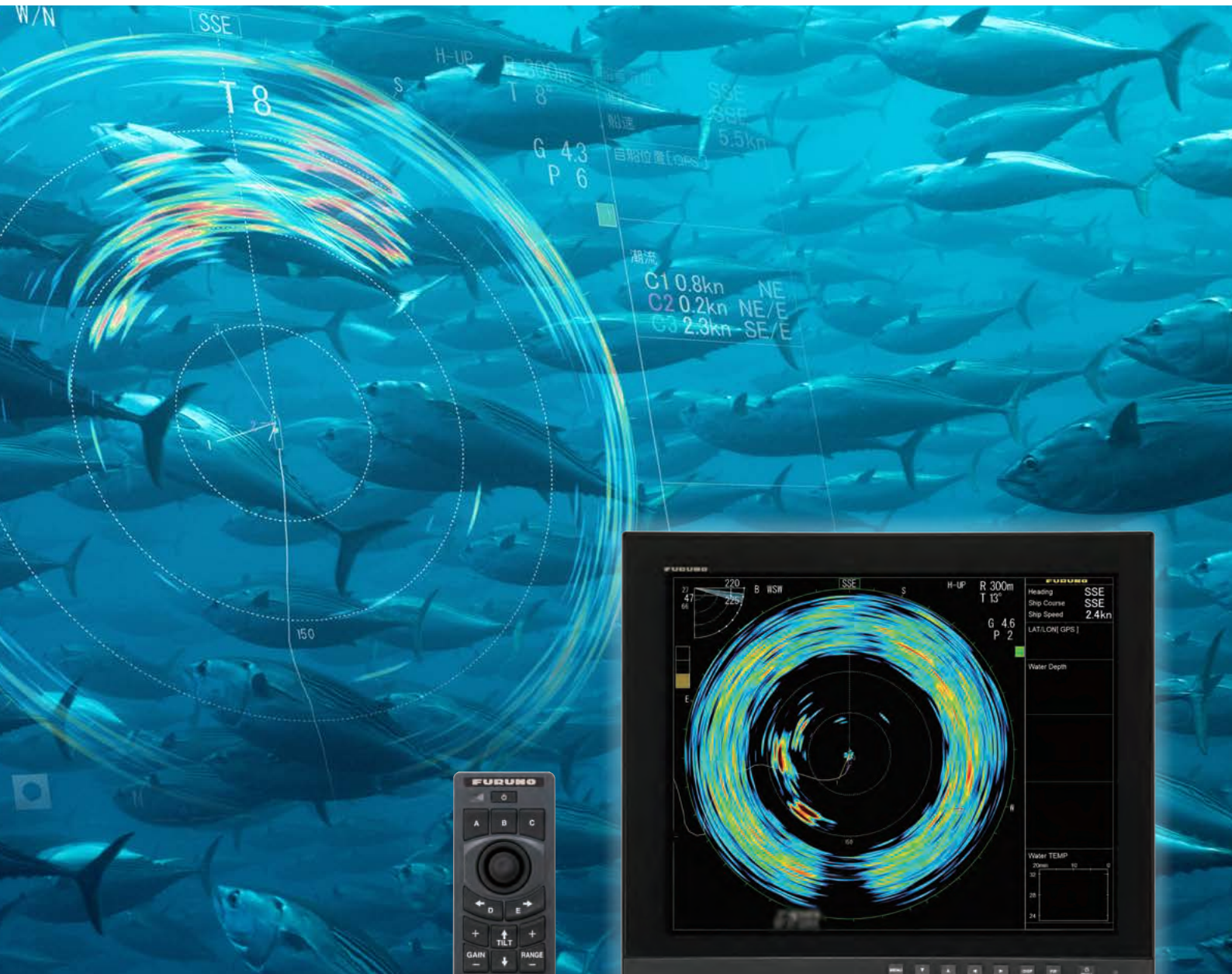

Photo: Furuno 19" Marine Display and  
Wireless Remote Controller  
(optional supply)

# Stable detection performance even in rough seas with high performing motion sensor!

The 360-Degree Omni Scanning Sonar CSH-10 detects all around your ship instantly, making it easy to grasp various undersea situations such as schools of fish, the seabed, and purse seine net. The 85 kHz high-frequency transmission provides enhanced detection performance to distinguish fish from the bottom and other underwater structures. With the sharp beam width, it is effective for detecting schools of fish near the surface. In addition, Furuno's unique beam stabilization technology, which is equipped with the motion sensor as standard, enables stable image even in rough seas.

- ▶ 85 kHz high-frequency Scanning Sonar clearly displays fish schools at the surface or on the seabed
  - ▶ Fish target monitoring during gear set and haul back
  - ▶ Sharp beam width effective for detecting surface fish schools
  - ▶ Furuno's unique beam stabilization with standard-supply motion sensor provides clear and stable images in rough seas
    - Boosts detection range
    - Stable fish echoes and vivid color display make it easier to identify your targets
    - Identify underwater structure and wrecks with ease
  - ▶ Displays ship's position, water temperature graph, tides, etc. \*
- \*Requires connection to various sensors.
- ▶ New compact control unit offers easy-to-understand operation

## 360-DEGREE OMNI SCANNING SONAR

Model **CSH-10**



- ▶ **CSH-10 is fully compatible with NavNet TZtouchXL series, allowing seamless integration and total control.**
- ▶ **New menu system with a user-friendly RotoKey™ and trackball for smooth and responsive operation**
- ▶ **Optional Wireless Remote Controller – Adjust your Sonar settings from anywhere on the boat\***  
\*Requires pairing with the Processor and Bluetooth® adapter. Connect up to 4 controllers.
- ▶ **Hoist travel twice as fast as previous model allows increased operation speed of 20 kn (18 kn max for raise/lower operations)**
- ▶ **Transducer dome cover protects against line chafe and impact**
- ▶ **CSH-10 uses common hull tanks for easy retrofit**



### What is 360-Degree Omni Scanning Sonar

360-Degree Omni Scanning Sonar simultaneously emits ultrasonic waves 360 degrees around the ship, instantly detecting and displaying images. Compared to Searchlight Sonar, its detection speed is much faster, and it can instantly detect the entire periphery, allowing continuous fish school tracking. It is suitable for detecting bonito and tuna, which swim quickly through the ocean.

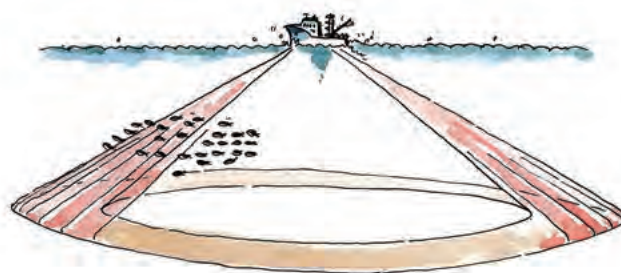

Scanning Sonar detection image

## “Beam stabilization” for clear and stable images in rough seas

The CSH-10 comes equipped with motion sensor as standard, and Furuno’s unique beam stabilization technology automatically adjusts the beam angle to correct beam fluctuation. The transmitting and receiving beams can be stabilized independently, allowing stable detection of schools of fish, even in rough weather.

Stabilizer ON

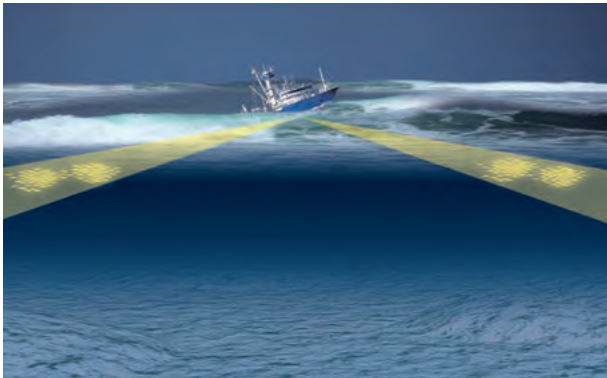

Stabilizer keeps the beam on the designated target.

Stabilizer OFF

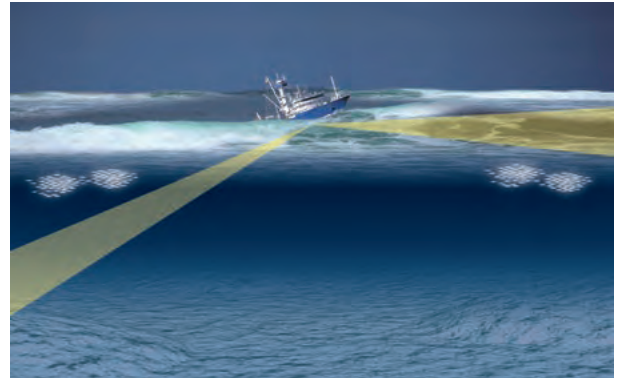

A beam affected by pitching and rolling falls to detect the target fish.

ON

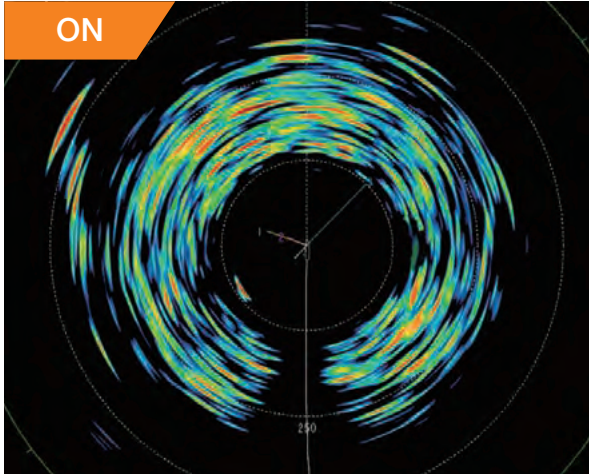

OFF

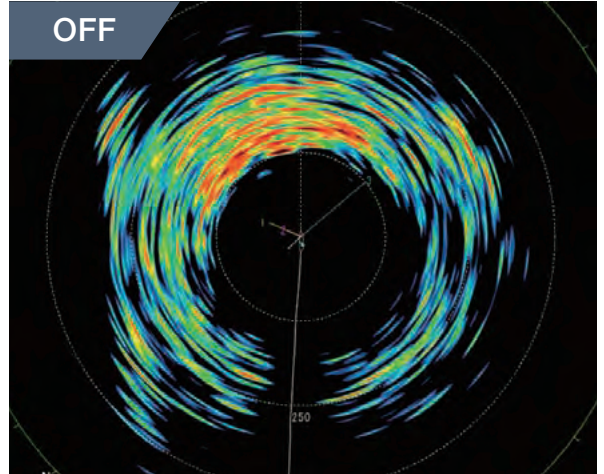

## Superior resolution for more accurate underwater imaging

Furuno’s unique Auto Filter function provides clearer images with less noise. Combined with the beam stabilization, this superior resolution image is very useful for identifying schools of fish and underwater structures.

## Improved detection performance

This is a comparison of screenshots of a shipwreck detected under the same conditions as the conventional model. Beam stabilization and signal processing technologies have eliminated false echoes, resulting in a clearer image.

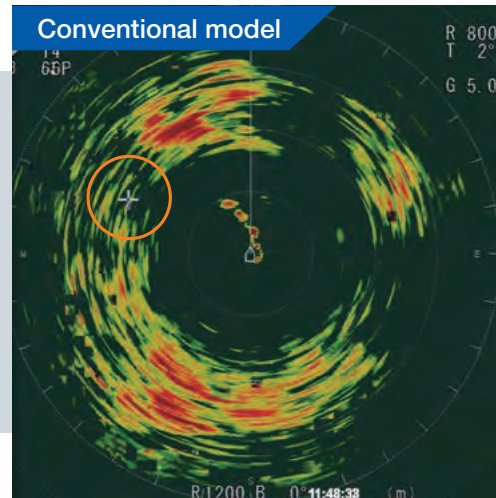
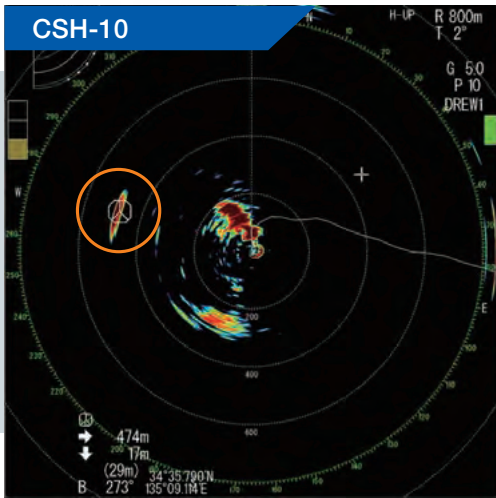

depth: 30 m, size of shipwreck length 40 m, height 5m

### ► Detection range up to an incredible 900 meters (over 2,900 feet)

The ability to detect schools of fish and structure further away is improved than ever before.

You can see the shipwreck image captured about 850 m away in the screenshot to the right. The built-in motion sensor has increased long-range target detection by 20% compared to the conventional model.

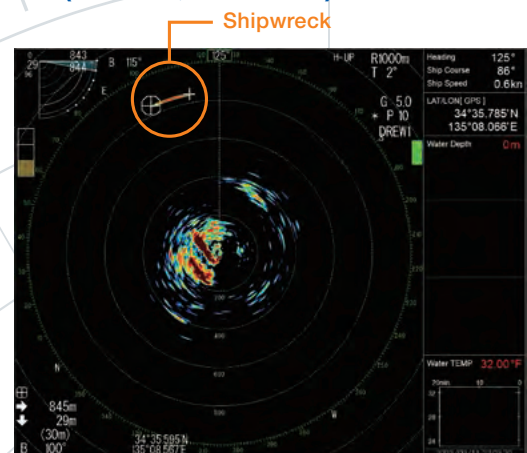

### ► Clear display of fish echo

The image display color has been increased from 16 colors in the previous model to 32 colors, allowing for clearer depiction of the light and dark shades of fish shadows.

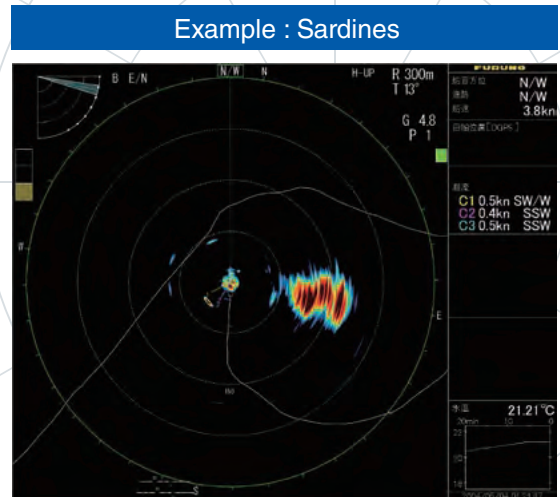
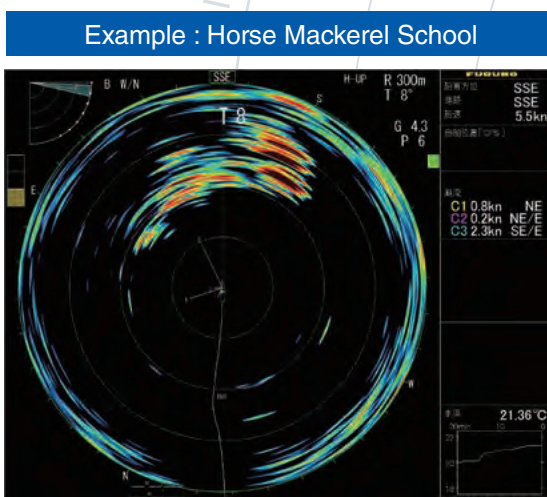

## Selectable Display modes

You can choose between a sonar display mode or a fish finder combined screen.

### Sonar

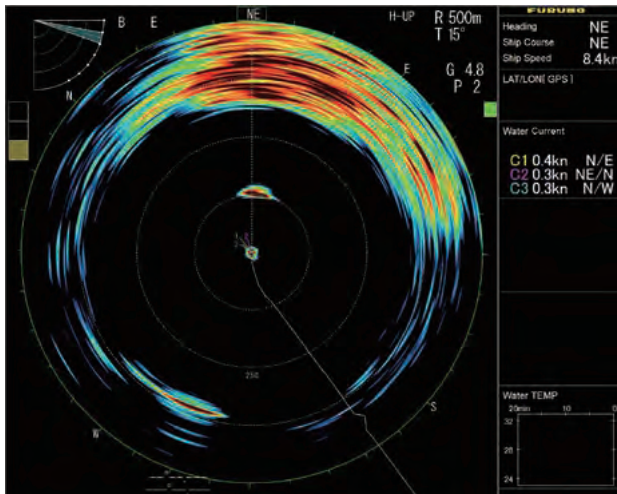

Navigation data can be displayed in the text window, with connection of appropriate sensors. This mode is useful for detecting and tracking schools of fish.

### Sonar with Fish Finder\*

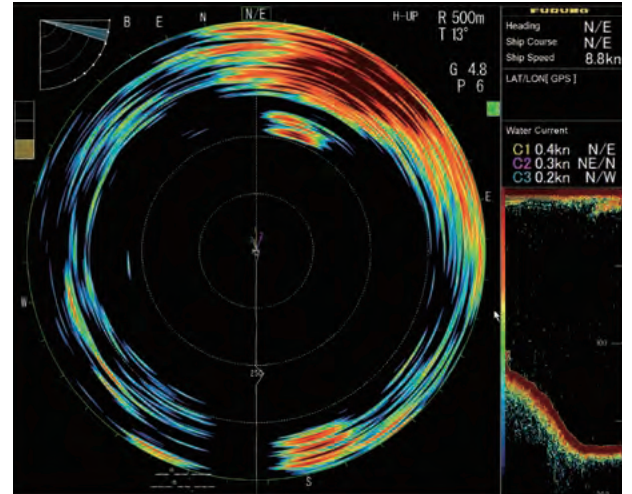

The sonar picture appears on the left and the signal fed from a fish finder at the lower right side of the screen.

This mode is suitable for assessing fish school concentration.

\*Connection to a fish finder is required.

## Compatible with NavNet TZtouchXL series\*

By connecting the scanning sonar CSH-10 to your TZtouchXL network, it is possible to display echoes, overlay charts, and operate and set up the device on the TZtouchXL display. You can control the CSH-10 intuitively by the touch operation, such as the tilt, indicator, sensitivity, etc. Overlaying it on the chart and the TZ BathVision contour lines greatly contributes to understanding the seabed topography and fish schools.

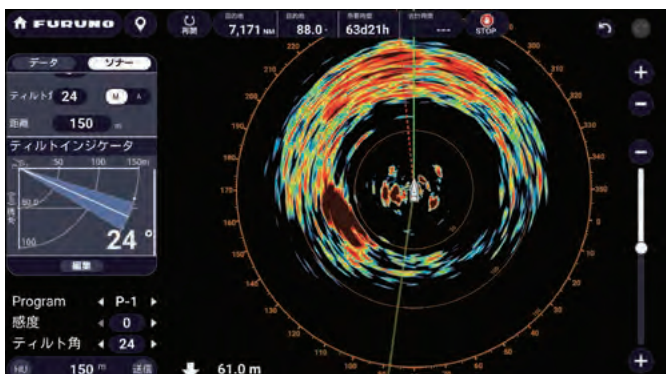

The sonar display on the TZtouchXL.

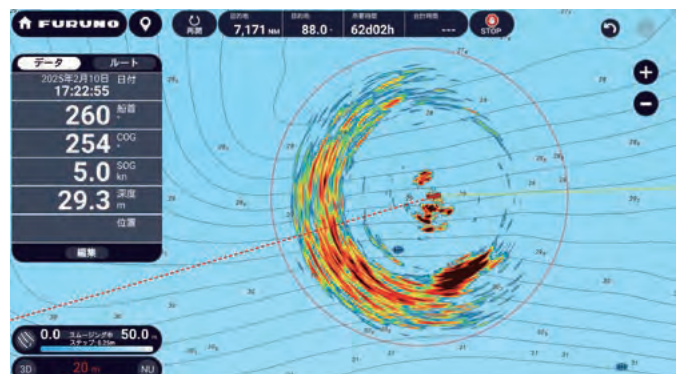

Overlaid sonar echo on chart display

\* TZtouchXL software version 25.11 or later required.

# Convenient functions to support your fishing

**NEW**

## ► Fish estimate mark measures fish school size

Utilizing the Fish estimate mark function, you can estimate the size of two schools of fish. This allows you to choose between target schools.

\*Requires vessel speed, course and heading data

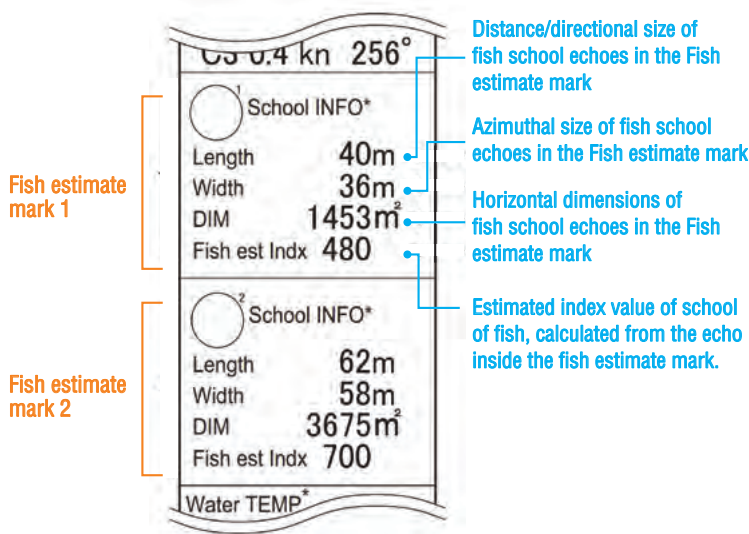
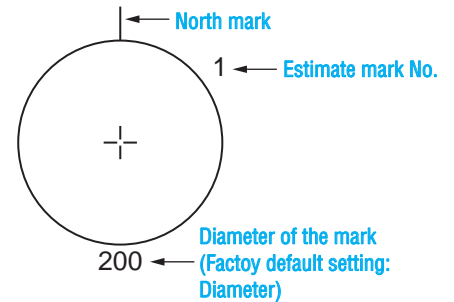

When a fish estimate mark is entered, information about the school is shown on the data display area.

The information shows the length, width, area, and Estimated index value of school of fish. The Estimate index number is a RATIO that provides a simple way to compare the current value of a fish/school echo to its surrounding mark circumference. An operator can then compare two echoes with two marks, allowing them to make informed decisions on which to target.

## ► Track schools of fish! “Target lock” function\*

The target lock function automatically tracks a school of fish and you will not lose sight of it on the display. It calculates and displays the distance from your ship to the school of fish, and the depth, the speed and the direction.

Two types of target lock modes are available: position tracking (Target Mark) and fish school tracking (Fish). When using position tracking mode, you can track a target reef or other object as a fixed position. \*Requires vessel speed, course and heading data

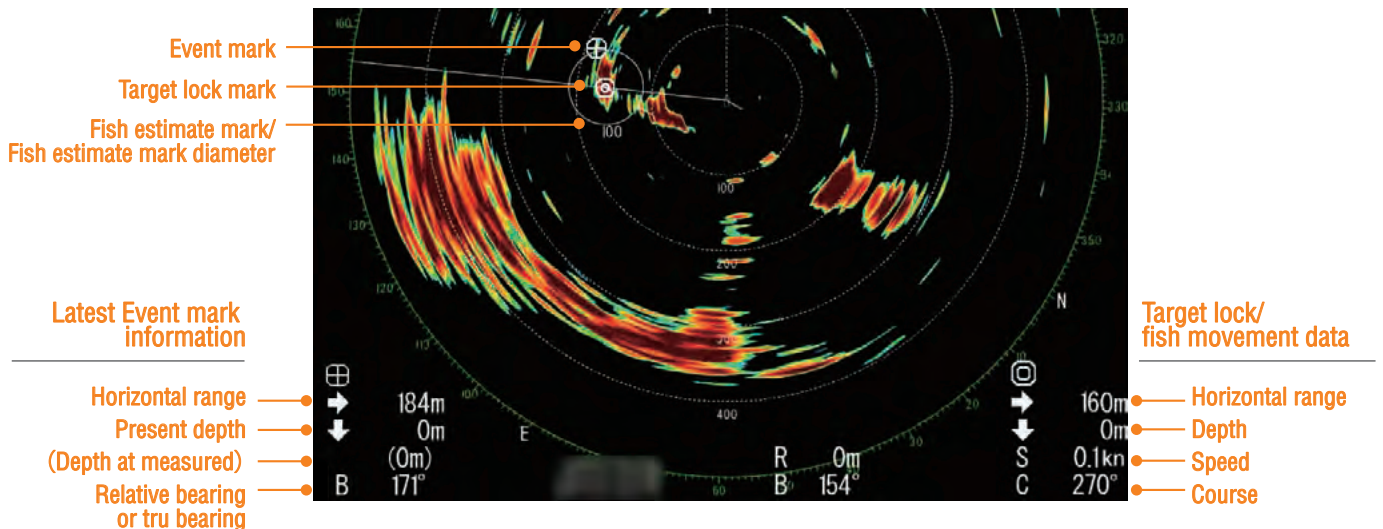

Placing an Event mark will provide distance, direction and depth to that mark, to be displayed on the screen.

## NEW

### ► Easy-to-see tilt display! “Tilt Indicator”

A tilt indicator is provided at the top left of the display screen. It displays the tilt angle, linear/horizontal/vertical distance to the cursor, beam detection range, and depth of the upper and lower ends of the beam width, allowing intuitive recognition of the echo position.

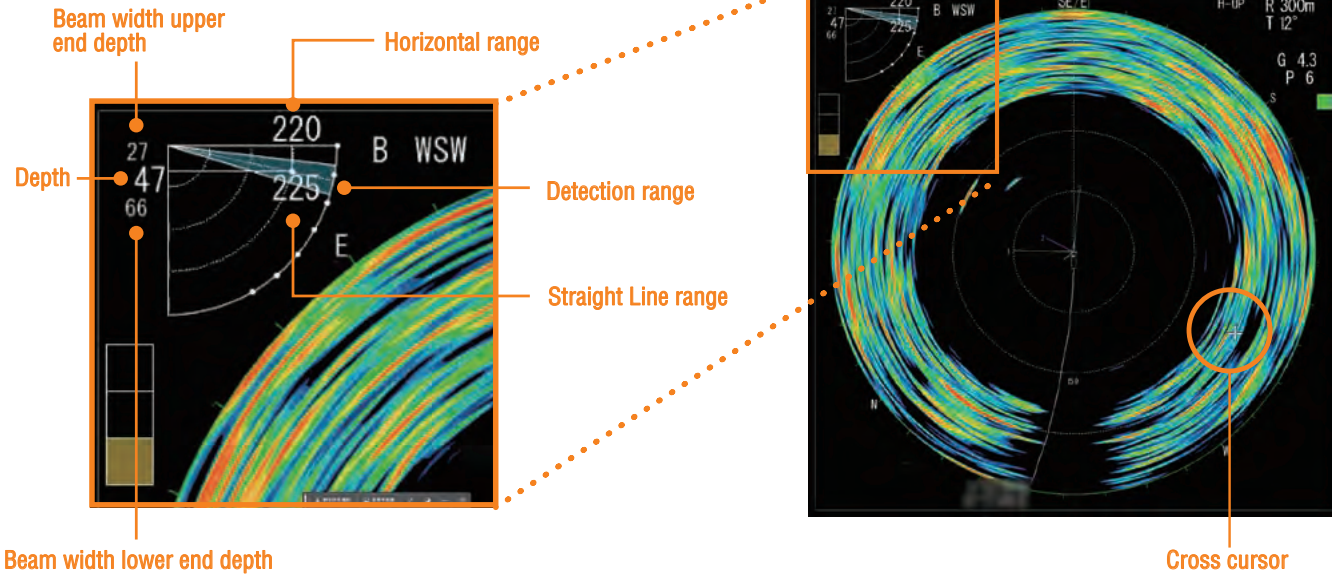
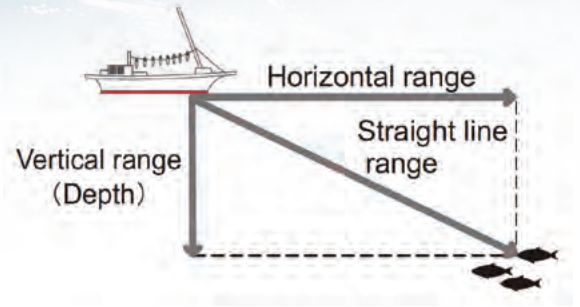

## Quick and reliable operation !

## NEW

### ► Intuitive new control unit

The control unit is smaller than the previous model, making it easier to install. In addition to the popular function keys, tilt lever, RotoKey™, and large trackball are available.



Control unit  
Model SCU-002



Remote controller (wired)\*  
Model FSV-854-MK2

▶ **“Echo data recording and playback function” is useful for reviewing**

You can save still and motion images. You can choose to save them to the built-in memory or an external storage device\*. Saved data can be easily played back from the menu screen.

\*Option

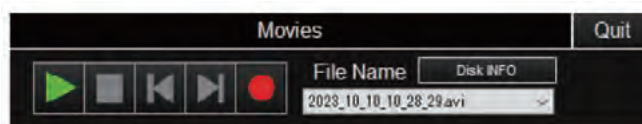
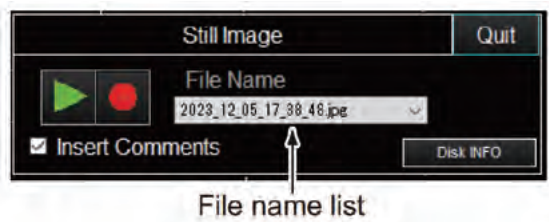

**NEW**

▶ **Control the CSH-10 remotely**

You can easily set the range, tilt angle, and sensitivity remotely, from the deck or fishing cockpit! Two types of remote controller are available: wired and wireless. Up to four wireless remote controller can be used via Bluetooth connection. We have also added a new small switch box to our lineup, which consists of only the power button, up/down button, and speaker, making it possible to control the rise/lower movement of the transducer from a distance.

The connection status of the wireless remote controller SCU-001 can be checked on the screen.



**Remote control status**

- Green : Remote Control Connected
- Red : Battery replacement is required
- No color : No remote control connection
- Out of range.

Remote control No. being registered. (paired)



Switch box\*

Model SCU-003

Remote controller (wireless)\*

Model SCU-001

\* Option

## ▶ Transducer position at a glance!

The transducer position indicator is available at the upper left corner of the screen. This indicator allows you to always check the operation and status of the transducer, helping you avoid accidents and increase safety at sea.

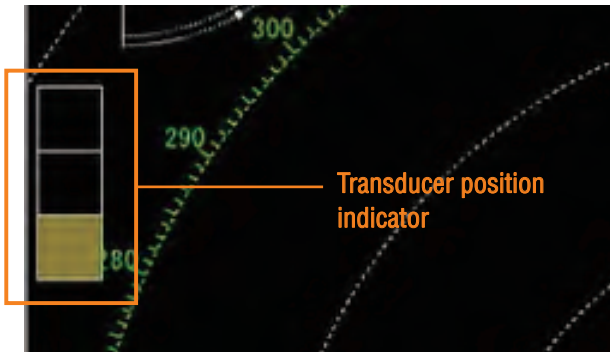

Transducer retracted



Transducer being raised



Transducer being lowered



Transducer deployed

## ▶ New transducer protective dome allows higher ship's speed allowance

Two types of Hull Units are available, with a 400 mm and 600 mm stroke. Increasing the speed of lifting transducer function achieves a lifting/lowering time of 7 seconds with a 400 mm stroke and 10 seconds with a 600 mm stroke. The usable ship speed is 20 kn in normal and 18 kn in operation, improved 2 kn each from the previous model\*.

CSH-10 uses the same hull tubes as CSH-8L MARK-2/CSH-5L MARK-2 for ease of retrofit.

\* If you are installing this on a high-speed vessel (vessel capable of traveling at 25 kt or more), please install a fin in front of the storage tank. For small FRP vessels, please use the optional fairing.

New transducer dome protects against object contact, line snags and corrosion.

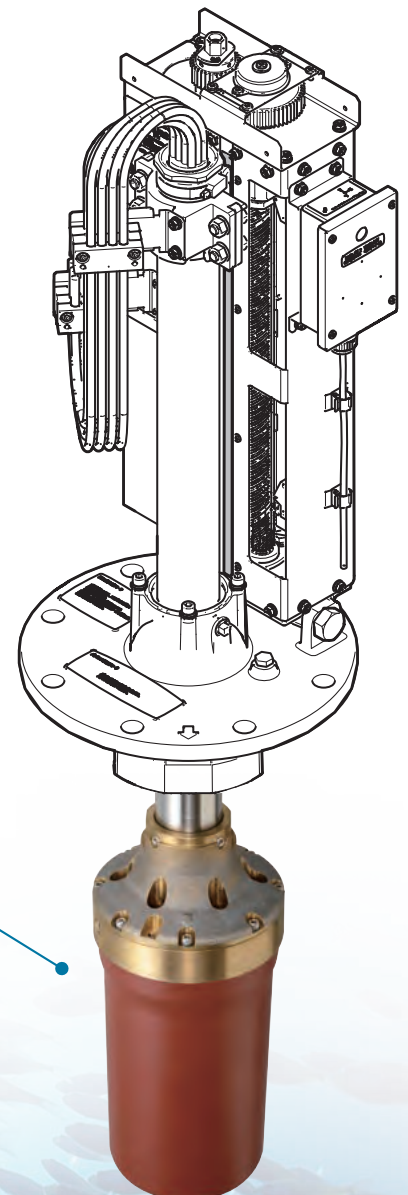

## SPECIFICATIONS

### 1. GENERAL

SCANNING METHOD	Full digital beam forming
Frequency	83.5 kHz (selectable between 81.5 and 85.5 kHz)
Pulse length	0.5 to 20 ms
Range	50, 100, 200, 300, 400, 500, 600, 700, 800, 900, 1000, 1100, 1200, 1400, 1600, 2000 m
Audio search	Frequency 1 kHz, Output 10 W (optional speaker required)

### 2. PROCESSOR UNIT

Orientation	Head-up, North-up* and Course up* (*sensor required)
Presentation mode	Vertical echo sounder, Echo sounder combination
Picture color	32 colors (sonar pictures), 6 colors (marks)
Marks	Own ship, Bow line, Bearing/Distance, Event, Fish school, Bearing scale, Tracking, Current
Information	Scan (Bearing/Distance), Cursor (Distance/Depth/Bearing), Event, Fish school (Position/Bearing), Own ship's location, Speed/Bearing, Water temperature
Features	Interference rejecter, Echo average, Noise limiter, Signal level, Automatic target tracking, Auto-retraction, Fish school alarm
Resolution	1280 x 1024 (SXGA)

### 3. HULL UNIT

Transducer travel	400 mm or 600 mm
Rise/lower time	7 s (400 mm travel), 10 s (600 mm travel)
Tx beam width	Horizontal: 360°, Vertical: 6°(-3dB at 83.5 kHz)
Rx beam width	Horizontal: 10°, Vertical: 9°(-3dB at 83.5 kHz)
Ship's speed allowance	20 kn (18 kn for raise/lower operation)

### 4. INTERFACE

#### Number of ports

Video output	2 ports, HDMI
NMEA0183	5 ports, V1.5/2.0/3.0/4.0/4.1
External KP	2 ports (Output 1, Input 1)
Audio output	1 port, 10 W, 4 ohms, monaural
Gyrocompass	1 port, AD-10
Echo sounder input	1 port, VI-1100A (analog)
Contact closure	1 port, for remote control or external switch
USB	4 ports, USB2.0: 2 ports, USB3.0: 2 ports
LAN	2 ports, Ethernet, 10/100/1000Base-T
Data sentences	
Input	CUR, DBS, DBT, DPT, GGA, GNS, HDG, HDM, HDT, MDA, MTW, RMC, VBW*, VDR, VHW, VTG, ZDA
Output	TLL

\* fore-aft/port-stbd speed data required

### 5. POWER SUPPLY

Transceiver Unit	24 VDC, 7.2 A max
Processor Unit	12-24 VDC: 4.0-2.0 A
Hull Unit	24 VDC, 10 A max

### 6. ENVIRONMENT

Ambient temperature	Processor/	
	Transceiver unit	-15°C to +55°C
	Transducer	-5°C to +35°C
	Hull Unit	IPX2
	Remote controller	IPX4 (FSV-854-MK2), IP5 (SCU-001)
	Small switch box	IP56 (front), IP22 (rear)

## EQUIPMENT LIST

### Standard

1. Processor Unit CSH-1003
2. Control Unit SCU-002
3. Transceiver Unit CSH-101
4. Hull Unit CSH-103: 400 mm or CSH-104: 600 mm travel
5. Installation Materials and Spare Parts

### Option

1. Control Unit SCU-002
2. Wired Remote Controller FSV-854-MK2 (Cable length 5/10 m)
3. Wireless Remote Controller SCU-001
4. Small Switch Box SCU-003
5. External Speaker SEM-21Q
6. Keyboard Mounting Bracket
7. SSD Assembly OP10-61
8. AC/DC Power Supply PR-241
9. Interface Unit IF-2550
10. Fairing 06-021-4502 (only for FRP resells)

## INTERCONNECTION DIAGRAM

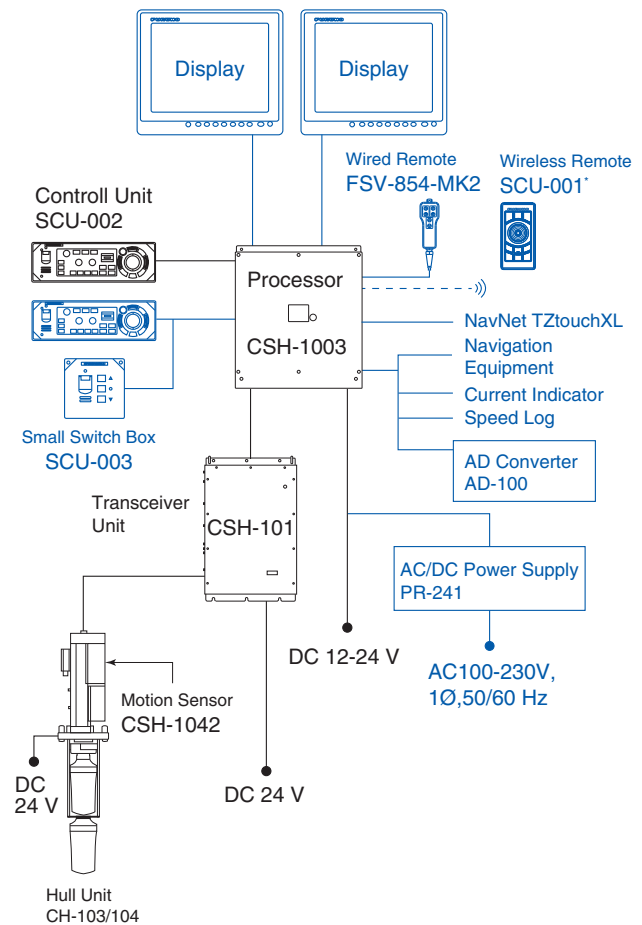

— Indicates optional or connectable equipment

\* Requires pairing with the Processor and Bluetooth® adapter

# 360-DEGREE OMNI SCANNING SONAR

Model **CSH-10**

## TRANSCIEVER UNIT CSH-101

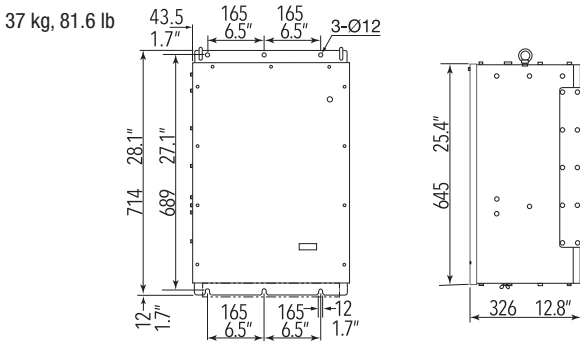

## PROCESSOR UNIT CSH-1003

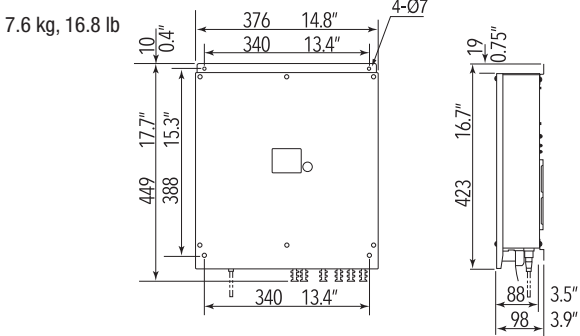

## HULL UNIT CSH-103/CSH-104

**CSH-103 (400 mm travel)**  
81 kg, 178.6 lb

**CSH-104 (600 mm travel)**  
87 kg, 191.8 lb

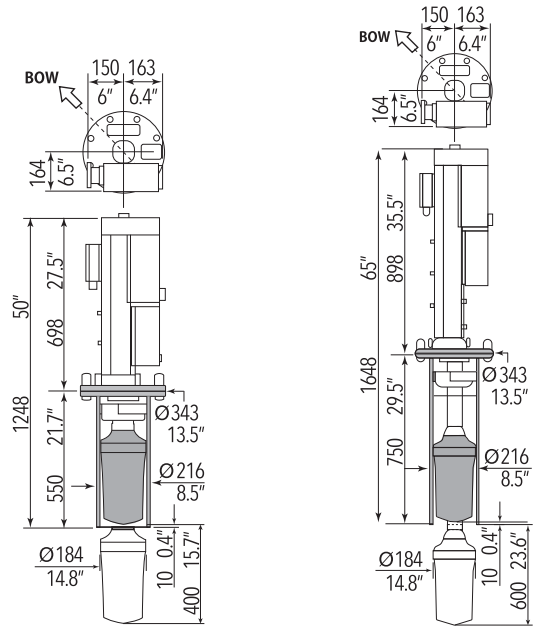

## CONTROL UNIT SCU-002

5m cable 1.2 kg, 2.6 lb  
10m cable 1.7 kg, 3.7 lb

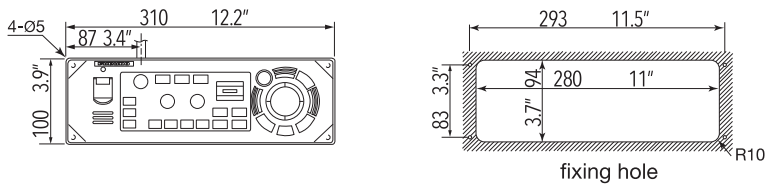

## FAIRING 06-021-4502 (option)

0.7 kg, 1.5 lb

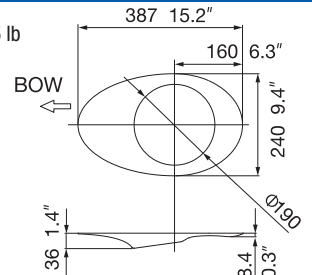

## REMOTE CONTROLLER (wired) FSV-854-MK2 (option)

0.76 kg, 1.68 lb

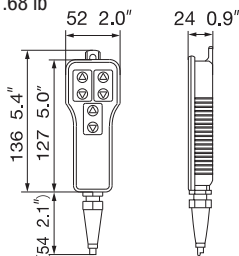

## REMOTE CONTROLLER (wireless) SCU-001 (option)

0.14 kg, 0.3 lb

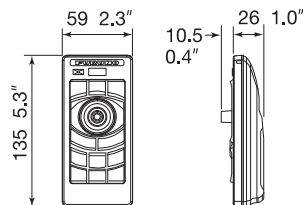

## SMALL SWITCH BOX SCU-003 (option)

0.2 kg, 0.4 lb

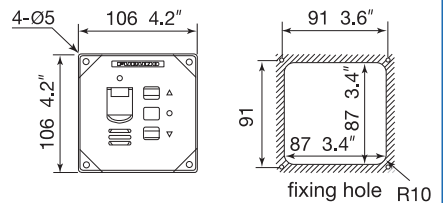

Beware of similar products

All brand and product names are registered trademarks, trademarks or service marks of their respective holders.

SPECIFICATIONS SUBJECT TO CHANGE WITHOUT NOTICE

**FURUNO ELECTRIC CO., LTD.**

www.furuno.com

Find your local contact point

